

www.vivafitness.net

VIVATM
FITNESS

#PushYourself



**STAY FIT.
ACCOMPLISH
MORE.**

Kevin Greene

PRODUCT CATALOGUE 2021

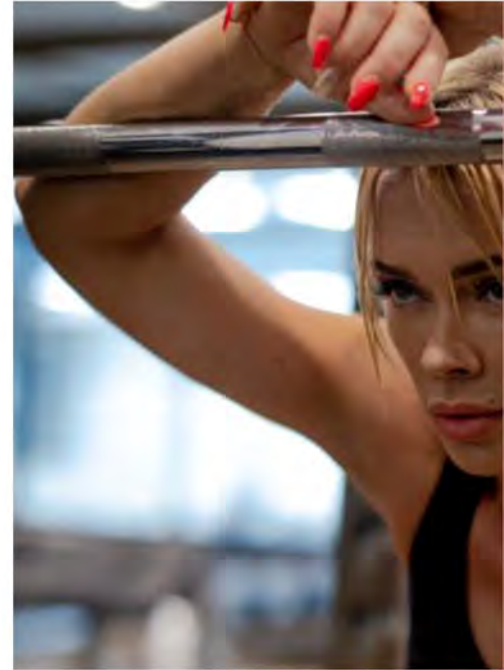

'Thoughts become things' when you leave the realm of average thinking and follow your dreams by applying the right decision, driven by your mind. Fitness is a 'state of mind', which needs constant trigger to put ones thought into action.

Every action needs a reason for accomplishing it. Staying fit manifests in the physicality and inner well-being which everyone aspires. Every time you make a resolve and step-up your fitness goals, life gets the better of you and positive thoughts lead to positive outcomes.

VIVA Fitness is an accomplished brand in the world of fitness equipment, designed for both commercial and home use. It thrives on the belief that with the right set of tools, a fitter person is better off in accomplishing his personal and professional goals.



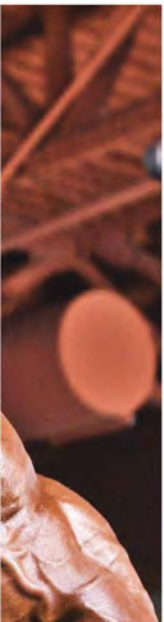
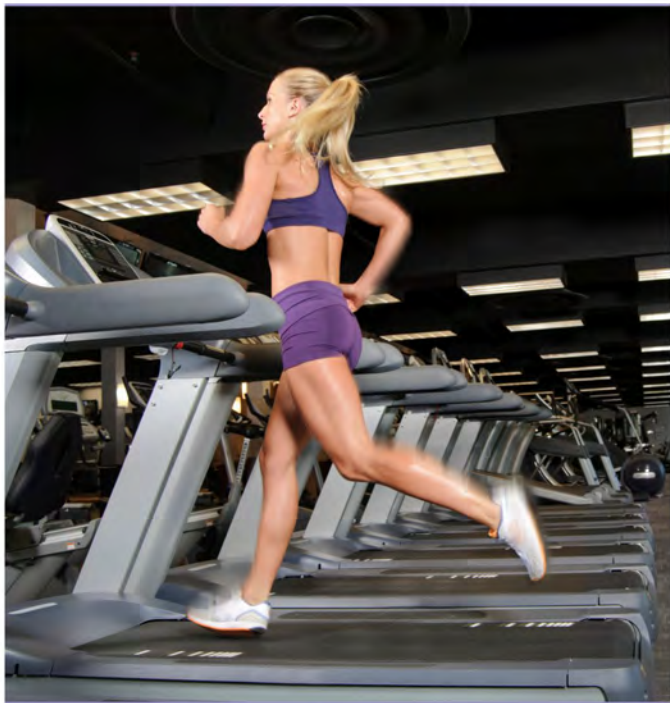

VIRTUAL X

COMMERCIAL TREADMILL



SPECIFICATIONS

- 21.5" capacitive touch screen
- AC driving system with adjustable variable frequency.
- 4.0 HP AC continuous (8.0 HP Peak) motor.
- 23" x 64" running surface.
- Speed : 1~20 kmph.
- Precise incline control from 0~15%.
- With intelligent inverter that detects speed variation and adjust automatically.
- Direct speed & incline keys on the console.
- Various motivating programs for different workout requirements.
- Extra heavy duty steel base with double cell neoprene rubber system for excellent suspension.
- 1" thick fibre board running deck.
- With cordless mobile charger.
- Heavy duty reliable 2 ply commercial grade German Siegling running belt.
- Large sized twin cup holder with a built-in tray.
- Emergency stop button.
- Sweat proof console design.
- Maximum User Weight : 180 Kgs.



T4444i

COMMERCIAL TREADMILL



SPECIFICATIONS

- **18.5" capacitive touch screen.**
- AC driving system with adjustable variable frequency.
- 5.0 HP AC continuous (10.0 HP Peak) motor.
- 23.5" x 65" running surface.
- Speed : 0.8~22 kmph.
- Precise incline control from 0~15%.
- With **intelligent inverter** that detects speed variation and adjust automatically.
- Direct speed & incline keys on the console.
- Various motivating programs for different workout requirements.
- Extra heavy duty steel base with double cell neoprene rubber system for excellent suspension.
- 1" thick fibre board running deck.
- With USB charger.
- Heavy duty reliable 2 ply commercial grade orthopaedic running belt.
- Large sized twin cup holder with a built-in tray.
- High speed O² generator.
- Emergency stop button.
- Sweat proof console design.
- Maximum User Weight : 180 Kgs.



T4444

COMMERCIAL TREADMILL



SPECIFICATIONS

- AC driving system with adjustable variable frequency.
- 5.0 HP AC continuous (10.0 HP Peak) motor.
- 23.5" x 65" running surface.
- Speed : 0.8~22 kmph.
- Precise incline control from 0~15%.
- Double 7" EBTN LCD display with colorful readout showing time, speed, distance, incline, calories, & heart rate.
- With **intelligent inverter** that detects speed variation and adjust automatically.
- Direct speed & incline keys on the console.
- Various motivating programs for different workout requirements.
- Extra heavy duty steel base with double cell neoprene rubber system for excellent suspension.
- 1" thick fibre board running deck.
- With USB charger.
- Heavy duty reliable 2 ply commercial grade orthopaedic running belt.
- Large sized twin cup holder with a built-in tray.
- High speed O² generator.
- Emergency stop button.
- Sweat proof console design.
- Maximum User Weight : 180 Kgs.



T2222

COMMERCIAL TREADMILL



SPECIFICATIONS

- AC driving system with adjustable variable frequency.
- 4.0 HP AC continuous (8.0 HP Peak) motor.
- 21.5" x 62" running surface.
- Speed 1~25 kmph.
- Precise incline control from 0~15%.
- 7 LED display with dot matrix showing time, speed, distance, incline, calories, & heart rate.
- Direct speed & incline keys on the console.
- Various motivating programs for different workout requirements.
- Extra heavy duty steel base with double cell neoprene rubber system for excellent suspension.
- 1" thick fibre board running deck.
- Heavy duty reliable orthopaedic running belt.
- Large sized, twin cup holder with a built in tray to hold your mobile phone, MP3 and ipod.
- High speed O² generator.
- Emergency stop button.
- Sweat proof console design.
- Maximum user weight: 180 kg.



T3300

COMMERCIAL TREADMILL



SPECIFICATIONS

- AC driving system with adjustable variable frequency.
- 4.5 HP AC continuous (9.0 HP Peak) motor.
- 24" x 65" running surface.
- Speed 0.8~25 kmph.
- Precise incline control from -3~18%
- Unique -3% declinable deck
- 6 LED display with dot matrix showing time, speed, distance, incline, calories, heart rate, steps, pace & average speed .
- Direct speed & incline keys on the console.
- Various motivating programs for different workout requirements.
- Extra heavy duty steel base with double cell neoprene rubber system for excellent suspension.
- 1" thick fibre board running deck.
- Heavy duty reliable orthopaedic running belt.
- Large sized, twin cup holder with a built in tray to hold your mobile phone,
- With USB charging point.
- High speed O² generator.
- Emergency stop button.
- Sweat proof console design.
- Maximum user weight: 180 kg.



T2525

COMMERCIAL TREADMILL



SPECIFICATIONS

- AC driving system with adjustable variable frequency.
- 4.5 HP AC continuous (9.0 HP Peak) motor.
- 23" x 67" running surface.
- Speed 1~22 kmph.
- Precise incline control from 0~15%
- 7 LED display with dot matrix showing time, speed, distance, incline, calories, heart rate, steps.
- Direct speed & incline keys on the console.
- Various motivating programs for different workout requirements.
- Extra heavy duty steel base with double cell neoprene rubber system for excellent suspension.
- 1" thick fibre board running deck.
- Heavy duty reliable orthopaedic running belt.
- Large sized, twin cup holder with a built in tray to hold your mobile phone.
- With USB charging point.
- MP3 connectivity with speakers.
- Emergency stop button.
- Sweat proof console design.
- Maximum user weight: 180 kg.



T2500

COMMERCIAL TREADMILL



SPECIFICATIONS

- AC driving system provides higher torque of power for heavy loading.
- 4 HP AC continuous (8.0 HP Peak) motor.
- 23"x 62" running surface.
- Speed range 0.8~25 kmph.
- Precise incline control from -3~15%.
- **Unique - 3% declinable deck.**
- Clear and luxurious design, 6 window LED display showing time, speed, distance, incline, calories, heart rate and matrix running.
- Various motivating programs for different workout requirements.
- Double phenolic heavy cushioned deck for excellent shock absorption that provides suitable push off to reduce the possibility of any type of injury to knees & joints.
- Heavy duty 3.1mm reliable orthopaedic running belt.
- Machine automatically reminds for lubrication.
- MP3 connectivity with speakers.
- Sweat proof console design.
- Two cup / bottle holders.
- Maximum user weight: 180 kg.



T1200

COMMERCIAL TREADMILL



SPECIFICATIONS

- AC driving system with adjustable variable frequency.
- 4.0 HP AC continuous (8.0 HP Peak) motor.
- Speed 0.5~22 kmph.
- Precise incline control from 0~18%.
- 22" x 63" running surface.
- 1 large screen with 6 small windows showing time, speed, distance, incline, calories & heart rate.
- Direct speed & incline keys on the console.
- Built in speakers & iPod / MP3 auxiliary jack / USB slot.
- Indication of fault for easy after sales service.
- Ipad holder.
- Various motivating programs for different workout requirements.
- Double phenolic heavy cushioned deck for excellent shock absorption that provides suitable push off to reduce the possibility of any type of injury to knees and joints.
- Heavy duty reliable orthopaedic running belt.
- Emergency stop button.
- Sweat proof console design.
- Two mobile / bottle holders.
- Maximum User Weight : 150 Kgs.



T2424

COMMERCIAL TREADMILL



SPECIFICATIONS

- AC driving system with adjustable variable frequency.
- 4.0HP AC continuous (8.0HP AC Peak) motor
- 22'x63' running surface
- Speed : 0.5~20 kmph
- Precise incline control from 1~18%
- LED display with clear readout showing time, speed, distance, incline, calories, heart rate
- With intelligent inverter that detects speed variation and adjust automatically
- Direct speed&incline keys on the console
- Various motivating programs for different workout requirements
- Extra heavy duty steel base with spring cushion for excellent suspension
- Thick fibre board running deck
- With MP3 for device voice display
- With USB port for charging
- With Bluetooth for connection of Kinmap, Zwift and Fit show app
- Heavy duty reliable 2 ply commercial grade orthopaedic running belt
- Emergency stop safety key
- Maximum user weight : 150 kgs



T2400

COMMERCIAL TREADMILL



SPECIFICATIONS

- AC driving system provides higher torque of power for heavy loading.
- 4.0 HP AC continuous (8.0 HP Peak) motor.
- 23" x 64" running surface.
- Speed 1~20 kmph.
- Precise incline control from 0~20%.
- Clear & luxurious design - 7 window white LED display showing time, speed, distance, incline, calories, heart rate & matrix running.
- Various motivating programs for different workout requirements.
- Double phenolic heavy cushioned deck for excellent shock absorption that provides suitable push off to reduce the possibility of any type of injury to knees and joints.
- Heavy duty 2.5mm reliable orthopaedic running belt.
- Mp3 & USB port connectivity with speakers.
- Sweat proof console design.
- Two cup / bottle holders.
- Maximum User Weight : 180 Kgs.



T2100

COMMERCIAL TREADMILL



SPECIFICATIONS

- AC driving system with adjustable variable frequency.
- 4.0 HP AC continuous (8.0 HP Peak) motor.
- Speed : 1~20 kmph.
- Precise incline control from 0 ~15%.
- **Unique -3% declinable deck.**
- 22" x 61" running surface.
- Multi window display showing time, speed, distance, incline, calories & heart rate.
- Direct speed & incline keys on the console.
- Various motivating programs for different workout requirements.
- Double phenolic heavy cushioned deck for excellent shock absorption that provides suitable push off to reduce the possibility of any type of injury to knees and joints.
- Heavy duty reliable orthopedic running belt.
- Emergency stop button.
- Sweat proof console design.
- Two Mobile/Bottle Holders.
- Maximum User Weight : 150 Kgs.



T2323

COMMERCIAL TREADMILL



SPECIFICATIONS

- AC driving system with adjustable variable frequency
- 4.0 HP AC continuous (8.0 HP Peak) motor
- Speed : 1~25 kmph
- Precise incline control from 0 ~25%
- 24" x 64" running surface
- 7 window with white LED showing time, speed, distance, incline, calories & heart rate.
- Direct speed & incline keys on the console
- Built in speakers & iPod/MP3 axillary jack/USB slot
- Various motivating programs for different workout requirements
- Double phenolic heavy cushioned deck for excellent shock absorption that provides suitable push off to reduce the possibility of any type of injury to knees and joints
- Heavy duty reliable orthopedic running belt
- Emergency stop button
- Sweat proof console design
- Two Mobile/Bottle Holders
- Maximum User Weight : 150 Kgs



X8

COMMERCIAL TREADMILL



SPECIFICATIONS

- AC driving system with adjustable variable frequency.
- 3.0 HP AC continuous (6.0 HP Peak) motor.
- Speed : 1~20 kmph.
- Precise incline control from 0 ~15%.
- 21" x 58" running surface.
- Multi window display showing time, speed, distance, incline, calories & heart rate.
- Direct speed & incline keys on the console.
- Various motivating programs for different workout requirements.
- Double phenolic heavy cushioned deck for excellent shock absorption that provides suitable push off to reduce the possibility of any type of injury to knees and joints.
- Heavy duty reliable orthopedic running belt.
- Emergency stop button.
- Sweat proof console design.
- Two Mobile/Bottle Holders.
- Maximum User Weight : 150 Kgs.



T2200

COMMERCIAL TREADMILL



SPECIFICATIONS

- AC driving system with adjustable variable frequency.
- 4.0 HP AC continuous (8.0 HP Peak) motor.
- 21" x 63" running surface.
- Speed 1~20 kmph.
- Precise incline control from 0~20%.
- 6 LED display with dot matrix showing time, speed, distance, incline, calories, & heart rate.
- Direct speed & incline keys on the console.
- Various motivating programs for different workout requirements.
- Extra heavy duty steel base with double cell neoprene rubber system for excellent suspension.
- 1" thick fibre board running deck.
- Heavy duty 4mm reliable German Siegling running belt.
- Large sized, twin cup holder with a built in tray to hold your mobile phone.
- MP3 and ipod connectivity with speaker.
- Emergency stop button.
- Sweat proof console design.
- Maximum user weight: 160 kg.



X7

COMMERCIAL TREADMILL



SPECIFICATIONS

- AC driving system provides higher torque of power for heavy loading
- 5.0 HP AC continuous (10.0 HP Peak) motor
- Speed 1~20 kmph
- Precise incline control from 1~20%
- 23" x 65" running surface
- Clear & luxurious design, 7 windows LED display showing time, speed, distance, incline, calories, heart rate & matrix running
- Various motivating programs for different workout requirements
- Double phenolic heavy cushioned deck for excellent shock absorption that provides suitable push off to reduce the possibility of any type of injury to knees and joints
- Heavy duty 3.1mm reliable orthopaedic running belt
- USB connectivity with speakers
- Sweat proof console design
- Two cup / bottle holders
- Maximum User Weight : 160 Kgs



X5

LIGHT COMMERCIAL TREADMILL



SPECIFICATIONS

- AC driving system with adjustable variable frequency.
- 3.0 HP AC continuous (6.0 HP Peak) motor.
- Speed : 1.5 ~ 18 KMPH.
- Incline : 0~15%.
- Running surface : 21 x 59 Inches.
- Readout :- time , speed, distance, incline, calories and program.
- Mp3 system.
- Built in speakers.
- 9 pre set program.
- **Unique deck system : soft in the front, medium in the center and hard in the end.**
- It protects the joints from injury and provide a good feeling while running.
- Heavy duty running belt.
- Maximum User Weight 135 kgs.



X3

LIGHT COMMERCIAL TREADMILL



SPECIFICATIONS

- AC driving system with adjustable variable frequency.
- 3.0 HP AC continuous (6.0 HP Peak) motor.
- Speed : 1~20 kmph.
- Precise incline control from 0 ~15%.
- 22" x 60" running surface.
- Multi window LED display showing time, speed, distance, incline, calories, Body fat & heart rate.
- Direct speed & incline keys on the console.
- Built in speakers with iPod/MP3 & auxiliary jack/USB slot.
- Various motivating programs for different workout requirements.
- Double phenolic heavy cushioned deck for excellent shock absorption that provides suitable push off to reduce the possibility of any type of injury to knees and joints.
- Heavy duty reliable orthopedic running belt.
- Emergency stop button.
- Sweat proof console design.
- Two Mobile/Bottle Holders.
- Maximum User Weight : 135 Kgs.



OMEGA 5

LIGHT COMMERCIAL TREADMILL



SPECIFICATIONS

- AC driving system with adjustable variable frequency.
- 3.0 HP AC continuous (6.0 HP Peak) motor.
- Speed : 1~18 kmph.
- Precise incline control from 0 ~18%.
- 20.5" x 60" running surface.
- Multi window LED display showing time, speed, distance, incline, calories, heart rate etc.
- MP3 connectivity with speakers.
- Various motivating programs for different workout requirements.
- High speed O² generator.
- Heavy duty reliable orthopedic running belt.
- Emergency stop button.
- Sweat proof console design.
- Two Mobile/Bottle Holders.
- Maximum User Weight : 135 Kgs.



T6666

CURVEMILL



SPECIFICATIONS

- Innovative curved deck.
- Non motorized technology.
- Comes with detachable waist strap that allows variety of pulling & pushing exercise.
- Display showing : distance, time, speed, pulse, calories & body fat.
- Exercise description : run, power walk, lateral shuffle & low push.
- With 6 resistance levels.
- Highly durable treadmill with low maintenance cost.
- Ideal for core strength & interval training.
- Long hand rails for maximum safety.
- 195 kgs heavy duty stable steel structure.
- Noise below 80 DB.
- Maximum user weight 180 kg.



MANUAL

LCD

T6464

CURVEMILL



SPECIFICATIONS

- Innovative curved deck.
- Non motorized technology.
- Display showing : distance, time, speed, pulse, calories & body fat.
Exercise description : run, power walk, lateral shuffle & low push.
- With 6 resistance levels.
- Highly durable treadmill with low maintenance cost.
- Ideal for core strength & interval training.
- Long hand rails for maximum safety.
- Maximum user weight 135 kg.



MANUAL

LCD

T007

INCLINE TRAINER



SPECIFICATIONS

- Unique patented Decline to Incline running deck -0.5 ~ 40%.
- Ideal for special training, for ex army, professional sports etc.
- AC driving system with adjustable variable frequency.
- 3.0 HP AC continuous (6.0 HP Peak) motor.
- Speed : 1~20 kmph.
- 21.5" x 61" running surface.
- 7" large window LED display showing time, speed, distance, incline, calories, heart rate etc.
- MP3 connectivity with speakers.
- Various motivating programs for different workout requirements.
- High speed O² generator.
- Heavy duty reliable orthopedic running belt.
- Emergency stop button.
- Sweat proof console design.
- Two Mobile/Bottle Holders.
- Maximum User Weight : 150 Kgs.



T008

MOUNTAIN TRAINER



SPECIFICATIONS

- Heavy duty structure.
- Ideal for special training. For ex. professional sports, army etc.
- Large LCD display showing time, speed, distance, calories, heart rate etc.
- Sweat proof console design.
- With adjustable magnetic resistance system.
- Extra 100 kgs weight plates can be added to increase the load.
- Maximum User Weight : 150 Kgs.



MANUAL

LCD

KH6050

FULL BODY TRAINER



SPECIFICATIONS

- New patented technology that offers user to choose between Climbing/Elliptical/Running/Bike stride
- LED dot matrix showing time, speed, distance, calories, RPM, pulse, watt & resistance
- Various motivating programs for different workout requirements
- Multi grip handle bar
- Variable stride length from 28" to 38" accommodating users of different heights
- Large pedals with toe caps for extra comfort
- Resistance Level : 0-16
- Reinforced frame for extra strength
- The large drink & accessories shelf is conveniently located with easy access while working out
- Maximum User Weight : 180 kgs



KH5060

COMMERCIAL ELLIPTICAL TRAINER



CONSOLE FEATURES

- Touch-sense technology is the most innovative user interface. Blue back-lighted sensor buttons clearly indicate exerciser to easy-start workout. Click-free buttons provide the best touch feeling.
- Built-in heart rate bar system could easily and precisely help to monitor the heart rate with both hand pulse and polar telemetry to achieve the individualized heart rate target for best workout result.
- 20 resistance levels.
- WATT-based heart rate program accurately achieve the target heart rate.
- Built-in test program offers the best reference for personal physical condition test and training.
- Large LED dot-matrix and scrolling text help exerciser to monitor workout.
- Full sets of programme for different training requirements , including 13 workouts.
- Precise watt control for accurate energy-managed workout.
- C-safe compatibility.
- High speed circulation fan.
- Ergonomic handle bar design for more comfortable exercise.
- Integrated tray for iPod.

INNOVATIVE FEATURES

- Cordless efficient self-powered system that offer continuous and smooth power.
- Enlarged and impact-absorbing pedals provide gentle movement to reduce lower back stress.
- 20" striding length provides sufficient workout experience to novice and professional user.
- Smart scrolling text guide user with easy-to start description to select exercise programme for personal fitness management.
- Enlarged touch buttons make it easy to operate and manage workout.
- Sweat-proof design.
- Various motivating programs selection for different exercise purposes.
- Quick-start function to start the exercise easily
- Precise watt control function for accurate energy-management exercises.
- Maximum user weight: 180 kg.



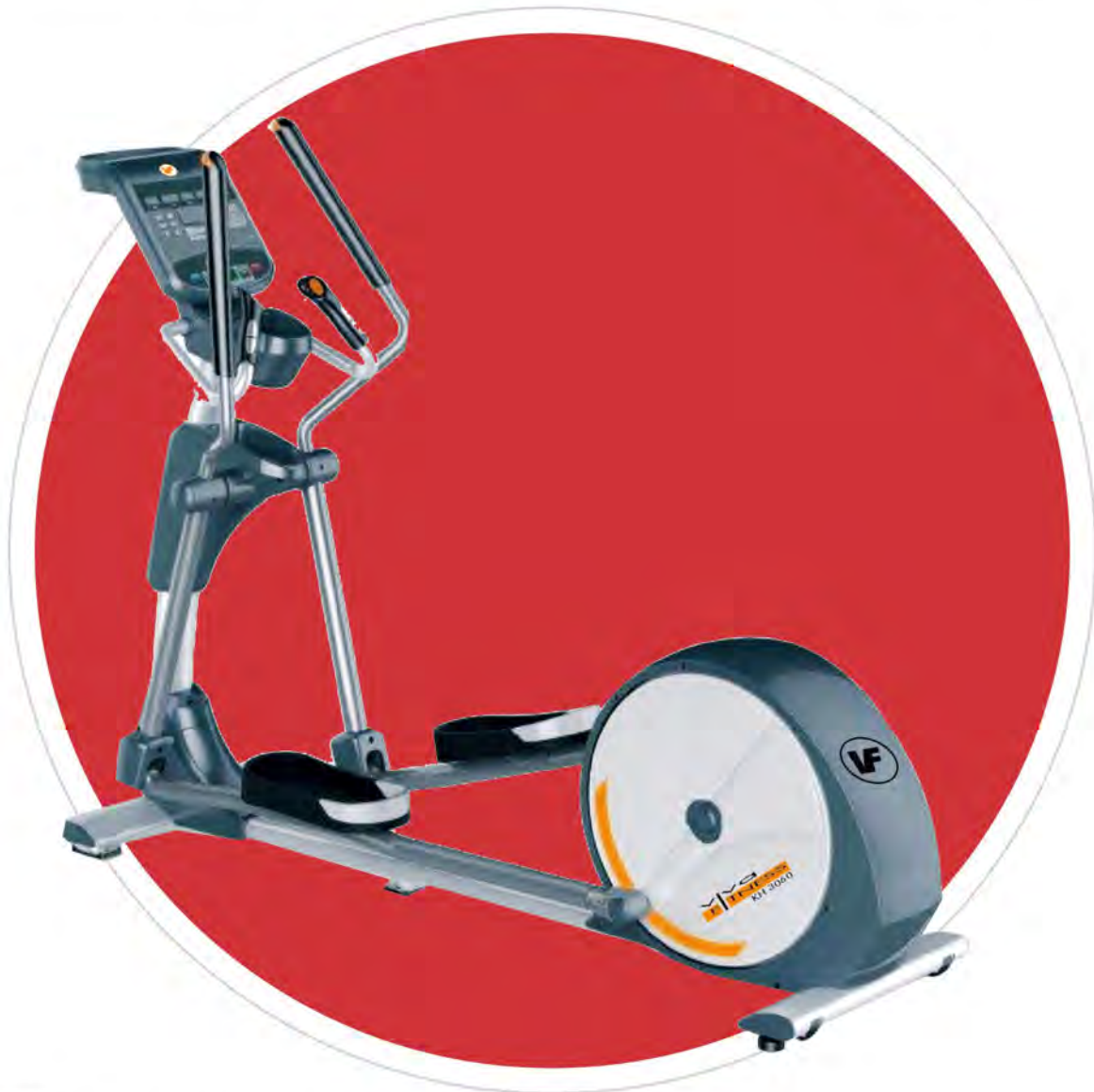

SPECIFICATIONS

DRIVE

- Rear-drive and handle arms enable sustain, smooth and engaging exercise, regardless your fitness level.
- Ergonomic multi position dual action handle bars.
- Large and impact-absorbing pedals (with gel pads) provide gentle movement to reduce lower back stress.
- Self- powered system, low maintenance design and space-saving deliver a fast return of investment.
- Power : Generator.
- Resistance level : 20

MONITOR

- Heart rate control programs provide user a challenging training.
- Multi readout summarizes workout result every minute, displays time used, distance covered, burned calories, watt and mets achieved.
- Reliable sweat-proof construction keeps console in demanding commercial environment.

SPECIAL FEATURES

- Offers various motivating programs for different workout requirements.
- Large LED's and intuitive keystroke permit easy-to-operation interface for change and monitor.
- Quick start key allows commencing exercise with a touch of button.
- Display function is switchable for feedback of Level, Watt, Mets and Pulse.
- Cup holder with towel handle.
- Maximum user weight : 180 kg.



KH2065

COMMERCIAL ELLIPTICAL TRAINER



SPECIFICATIONS

DRIVE

- Two stage drive with poly V-belt.
- Resistance System : New Technology silent programmable magnetic resistance system.
- Resistance Level : 36 Levels.

MONITOR

- Advanced computer with 7" LCD blue Back-Lit screen.
- Display readouts : Time, Distance, RPM, Speed, Level, Calories, Pulse and Watts.
- 14 Programs, including 10 Manual, 4 HRC & 2 User set.

SPECIAL FEATURES

- 20 inches long stride for ultimate workout.
- Both forward and reverse motions offer various workout options.
- Low impact workout.
- Comfy over-sized, non-slip pedals.
- Hand-held pulse sensors.
- Dual action handlebars with high density foam grips.
- Built-in speakers & Ipad / MP3 auxillary jack.
- Ipad / Ipod charging station.
- High speed circulation fan that allows the user to stay cool during workout.
- Accessory tray & built-in reading rack.
- Transport wheels.
- Adjustable Floor Levelers.
- Built-in Receiver.
- Maximum User Weight : 180 Kgs.



KH4080

OCTAVIA



SPECIFICATIONS

- LED dot matrix showing time, speed, distance, calories, RPM, pulse, watt & resistance.
- Various motivating programs for different workout requirements.
- Multi grip handle bar.
- 20" stride length.
- 14kgs flywheels.
- Cushioned paddles for extra comfort.
- Console includes fan & bluetooth .
- Re-inforced frame for extra strength.
- With bottle holder.
- Maximum User Weight : 140 Kgs.



E600

COMMERCIAL ELLIPTICAL TRAINER



SPECIFICATIONS

- LED dot matrix console readouts: INCLINE, TIME, DISTANCE, CALORIES, PULSE, SPEED / RPM, LEVEL, WATT, FAN etc.
- Various motivating programs for different workout requirements.
- Level Control : 20 resistance levels.
- With 15 level power incline.
- 500mm x 220mm unique stride length.
- 12 kgs flywheel.
- Both forward & reverse motions offer various workout options
- Hand held pulse sensors enable to monitor the heart rate all times.
- Mp3 with speaker and USB charger.
- With O2 generator and bottle holder.
- Unique durable floor levelers on front & rear stabilizer.
- With adaptor power system.
- Maximum user weight : 150 kg



KH2075

COMMERCIAL ELLIPTICAL TRAINER



SPECIFICATIONS

Drive

- Front-drive and handle arms enable sustain, smooth & engaging exercise, regardless your fitness level.
- Large & impact-absorbing pedals provide gentle movement to reduce lower back stress.
- Self-powered system, low maintenance design & space-saving deliver a fast return of investment.
- Striding distance : 500 mm (20").
- Power : Generator.
- Resistance level : 40.

Monitor

- Heart rate control programs provide user a challenging training.
- Multi readout summarizes workout result every minute, displays time used, distance covered, burned calories, watt and mets achieved.
- Reliable sweat-proof construction keeps console in demanding commercial environment .

Special Features

- Offers 4 programs and upto 40 resistance levels to keep fitness routine effective and fresh.
- Large LED's and intuitive keystroke permit easy to operate interface for change and monitor.
- Quick start key allows commencing exercise with a touch of a button.
- Display function is switchable for feedback of Level, Watt, Mets and Pulse.
- Maximum User Weight : 150 Kgs.



KH2050

COMMERCIAL ELLIPTICAL TRAINER



SPECIFICATIONS

DRIVE

- Rear-drive and handle arms enable sustain, smooth and engaging exercise, regardless your fitness level.
- Large and impact-absorbing pedals provide gentle movement to reduce lower back stress.
- Self- powered system, low maintenance design and space-saving deliver a fast return of investment.
- Striding distance : 500 mm (20").
- Power : Generator.
- Resistance level : 16.

MONITOR

- Heart rate control programs provide user a challenging training.
- Multi readout summarizes workout result every minutes , displays time used, distance covered, burned calories, watt and mets achieved.
- Reliable sweat-proof construction keeps console in demanding commercial environment.

SPECIAL FEATURES

- Offers 6 programs and upto 16 resistance levels to keep fitness routine effective and fresh.
- Large LED's and intuitive keystroke permit easy-to-operation interface for change and monitor.
- Quick start key allows commencing exercise with a touch of button.
- Display function is switchable for feedback of Level, Watt, Mets and Pulse.
- Maximum user weight : 150 kg.





SPECIFICATIONS

DRIVE

- Front-drive and handle arms enable sustain, smooth and engaging exercise, regardless your fitness level.
- Large and impact-absorbing pedals provide gentle movement to reduce lower back stress.
- Self- powered system, low maintenance design and space-saving deliver a fast return of investment.
- Striding distance : 500 mm (20").
- Power : Generator.
- Resistance level : 16.

MONITOR

- Heart rate control programs provide user a challenging training.
- Multi readout summarizes workout result every minutes , displays time used, distance covered, burned calories, watt and mets achieved.
- Reliable sweat-proof construction keeps console in demanding commercial environment.

SPECIAL FEATURES

- Offers 4 programs and upto 16 resistance levels to keep fitness routine effective and fresh.
- Large LED's and intuitive keystroke permit easy to operate interface for change and monitor.
- Quick start key allows commencing exercise with a touch of button.
- Display function is switchable for feedback of Level, Watt, Mets and Pulse.
- Maximum user weight : 150 kg.





SPECIFICATIONS

- Rear drive and handle arms enable smooth and full body workout.
- Large and impact absorbing pedals provide gentle movement to reduce lower back stress.
- Friction free electro magnetic resistance : 16 levels.
- Striding distance : Maximum 20" with natural movement.
- With adapter power system.
- 21 programs for different workout requirements.
- Built in hand grip pulse sensors.
- Large LCD display to show time, distance, RPM, calories, pulse, resistance level & watt.
- Quick start key allows commencing exercise with a touch of a button.
- Extra sturdy & stable steel frame construction.
- Easy transportation with wheels in the front.
- Maximum User Weight : 150 Kgs.



E200

LIGHT COMMERCIAL ELLIPTICAL TRAINER



SPECIFICATIONS

- LED dot matrix console readouts: TIME, DISTANCE, CALORIES, PULSE, SPEED / RPM, LEVEL, WATT, FAN etc.
- Various motivating programs for different workout requirements.
- Level Control : 24 resistance levels.
- Dual Technology - resistance with both magnetic and air.
- 520mm x 240mm unique stride length.
- 8 kgs flywheel.
- Both forward & reverse motions offer various workout options.
- Hand held pulse sensors enable to monitor the heart rate all times.
- With ipad holder & bottle cage.
- Unique durable floor levelers on front & rear stabilizer.
- Transport wheels on the front stabilizer, providing easy movement to move the items.
- With adaptor power system.
- Maximum user weight : 150 kg.





SPECIFICATIONS

- Front-drive and handle arms enable sustain, smooth and engaging exercise, regardless your fitness level.
- Long stride length for different user heights.
- Auto scan advanced computer with blue back-lit screen.
- Display Readouts : Time, Distance, RPM, Speed, Level, Calories, Pulse and Watts.
- Magnetic brake with V-belt drive system.
- 16 levels tension control system.
- 12 programs, including 1 manual, 2HRC, 1 body fat and 2 user set.
- With adapter power system.
- Hand-held pulse sensor.
- Aluminum upright beam.
- Hidden 3 pcs cranks inside crank cover for safety & good looking.
- Transport wheels.
- Adjustable floor levelers.
- Maximum user weight: 130 kg.



KH630

LIGHT COMMERCIAL ELLIPTICAL TRAINER



SPECIFICATIONS

- 20" long stride.
- 24 Level resistance.
- 0-15% manual incline.
- 5" LCD display readouts : Time, Distance, RPM, Speed, Calories, Pulse and Watts.
- Multiple programs available.
- Handheld pulse sensor.
- With adapter power system.
- Transport wheels.
- Adjustable floor levelers.
- Maximum User Weight : 130 Kgs.



KH595

LIGHT COMMERCIAL ELLIPTICAL TRAINER



SPECIFICATIONS

- Front Drive with long handle arms enabling smooth and engaging exercise regardless your fitness level
- With 3 level manual incline
- 20" Long stride length for different user heights
- Auto scan advanced computer with blue back-lit screen
- Display Readouts : time, distance, RPM, speed, level, calories, pulse & watts
- Magnetic brake with V-belt drive system
- With 7 kg flywheel
- With 3 pcs hidden crank system
- 16 levels tension control system
- Multiple programs, including 1 manual, 2 HRC, 1 body fat & 2 user set
- Hand held pulse sensor
- With adapter power system
- Transport wheels
- Adjustable floor levellers
- Maximum user weight : 130kgs



KH580

LIGHT COMMERCIAL ELLIPTICAL TRAINER



SPECIFICATIONS

- 18" long stride.
- Adjustable swing bar.
- LCD display readouts : Time, Distance, RPM, Speed, Calories, Pulse and Watts.
- Multiple programs including 1 Manual, 4 HRC, 3 Goal and 5 Users.
- Handheld pulse sensor.
- 30 cm fly wheel.
- Motor magnetic 24 level resistance.
- With adapter power system.
- Transport wheels.
- Adjustable floor levelers.
- Maximum User Weight : 130 Kgs.





SPECIFICATIONS

- 20" long stride length with 2 levels of adjustment.
- Adjustable swing bar.
- Display readouts : Time, Distance, RPM, Speed, Calories, Pulse, Body ratio, BMI, BMR and Temperature.
- Handheld pulse sensor.
- 10 kgs fly wheel.
- Magnetic 8 level manual tension control system.
- Transport wheels.
- Adjustable floor levelers.
- Maximum User Weight : 130 Kgs.



KH5040

COMMERCIAL RECUMBENT BIKE



SPECIFICATIONS

- Touch-sense technology is the innovative user interface. Blue back-lighted sensor buttons clearly indicate runner to easy-start workout. Click-free buttons provide the best touch feeling.
- Built-in heart rate bar system could easily and precisely help to monitor the heart rate with both hand pulse and polar telemetry to achieve the individualized heart rate target for best workout result.
- 20 resistance levels.
- WATT-based heart rate programme accurately achieve the target heart rate.
- Built-in test programme offers the best reference personal physical condition test and training.
- Large LED dot-matrix and scrolling text help exerciser to monitor workout.
- Precise watt control for accurate energy-managed workout.
- C-safe compatibility.
- High speed circulation fan.
- Ergonomic handle bar design for more comfort exercise.
- Integrated tray for iPod.
- Cordless efficient self-powered system that offer continuous and smooth power since lower speed. The recumbent bike could be placed anywhere.
- Patented sliding seat system provides the maximum convenience and stability. The ergonomic seat can be firmly fixed in any position for best workout position.
- 28 levels width pedal adjustment for any size of foot to protect ankles during exercise.
- Self-tension-adjusted driving belt system
- Step-through design provides convenience for both male and female to seat on the bike.
- Height-adjustable foot for stabilizing recumbent bike on any ground surface.
- Aluminum sliding rack.
- Aluminum forged pedal crank.
- Maximum user weight: 180 kg.



KH3040

COMMERCIAL RECUMBENT BIKE



SPECIFICATIONS

DRIVE

- Two stage drive with poly V-belt.
- Resistance System : Self powered hybrid brake.
- Resistance Level : 20 Levels.

MONITOR

- 7 window dot matrix LED display.
- Display readouts : Time, Distance, RPM, Speed, Level, Calories, Pulse and Watts.
- Various motivating programs for different workout requirements.

SPECIAL FEATURES

- Back cushion with various adjustable angles.
- The easy-to-operate adjustment bar to move the seat forward and backward.
- Walk-through design to get on / off easily.
- Accessory tray with cup holder.
- Seat handle bars with quick access resistance (+/-) keys and handheld pulse sensors.
- Adjustable pedal straps
- Aluminum upright beam
- Hidden 3 piece cranks inside crank cover for safety
- Transport wheels
- Adjustable floor levelers
- Built-in receiver
- Maximum User Weight : 180 kgs



KH2045

COMMERCIAL RECUMBENT BIKE



SPECIFICATIONS

DRIVE

- One stage drive with poly V-belt.
- Resistance System : Self powered generator brake.
- Resistance Level : 36 Levels.

MONITOR

- Advanced computer with 7" LCD blue Back-Lit screen.
- Display readouts : Time, Distance, RPM, Speed, Level, Calories, Pulse and Watts.
- 14 Programs, including 10 Manual, 2 HRC, 2 User set.

SPECIAL FEATURES

- Innovative back cushion with various adjustable angles.
- The easy-to-operate adjustment bar to move the seat forward and backward.
- Walk-through design to get on / off easily.
- Seat handle bars with quick handheld pulse sensors.
- Adjustable pedal straps.
- 3 piece cranks.
- Built-in speakers & Ipad / MP3 auxillary jack.
- Ipad / Ipod charging station.
- High speed circulation fan that allows the user to stay cool during workout.
- Accessory tray, built-in reading rack, rechargeable batteries.
- Transport wheels.
- Adjustable floor levelers.
- Built-in receiver.
- Maximun User Weight : 180 Kgs.



KH1140

COMMERCIAL RECUMBENT BIKE



SPECIFICATIONS

- Dot matrix LED display showing Pulse, Recovery, Time, RPM, Speed, Distance, Calories, Watt, Heart Rate & Resistance.
- With self generator system.
- 12 programs : 4 HRC, 3 goal, 1 recovery and 4 user.
- Magnetic brake with V-belt drive system.
- 16 levels tension control system.
- Ergonomic seat adjustment.
- With heart rate receiver.
- Hand grips with pulse sensor.
- Counter balance pedals.
- With bottle holder.
- Adjustable PU seat.
- Transport wheels.
- User weight : 150 kgs.



KH1040

COMMERCIAL RECUMBENT BIKE



SPECIFICATIONS

- LED display showing Pulse, Recovery, Time, RPM, Speed, Distance, Calories, Watt, Heart Rate and Resistance.
- With self generator system.
- 12 programs, including 1 manual, 4 HRC, 2 test, 1 recovery and 4 user.
- Magnetic brake with V-belt drive system.
- 16 levels tension control system.
- Ergonomic seat adjustment.
- With heart rate receiver.
- Hand grips with pulse sensors.
- Counter balance pedals.
- With bottle holder.
- Adjustable PU seat.
- Transport wheels.
- User weight : 140 kg.



KH820

LIGHT COMMERCIAL RECUMBENT BIKE



SPECIFICATIONS

- Auto scan advanced computer with blue BACK-LT LCD screen.
- 12 programs, including 1 manual, 2 HRC, 1 body fat, 2 user set.
- Display showing Pulse, Recovery, Time, RPM/Speed, Distance, K joule or Calories, Watt/Target Heart rate, Fat%, BMI, BMR, Body Type.
- Magnetic brake with V-belt drive system.
- 16 levels tension control system.
- With adapter power system.
- Innovative adjustment end cap, easy to go with uneven floor.
- Aluminum upright & seat rails.
- PU seat & back rest.
- Easy to adjust seat position.
- Hand grip pulse sensors.
- Hidden crank(3pcs) safer & neat.
- Transport wheels.
- Maximum user weight: 130 kg



KH3020

COMMERCIAL UPRIGHT BIKE



SPECIFICATIONS

DRIVE

- Two stage drive with poly V-belt.
- Resistance System : Self powered hybrid brake.
- Resistance Level : 20 Levels.

MONITOR

- 7 window dot matrix LED display.
- Display readouts : Time, Distance, RPM, Speed, Level, Calories, Pulse and Watts .
- Various motivating programs for different workout requirements.

SPECIAL FEATURES

- Various seat height level adjustments.
- Accessory tray with cup holder.
- Adjustable pedal straps.
- Aluminum upright beam.
- Hidden 3 piece cranks inside crank cover for safety.
- Transport wheels.
- Adjustable floor levelers.
- Built-in receiver.
- Maximum User Weight : 180 kgs.



KH2025

COMMERCIAL UPRIGHT BIKE



SPECIFICATIONS

DRIVE

- One stage drive with poly V-belt.
- Resistance System : Self powered generator brake.
- Resistance Level : 36 Levels.

MONITOR

- Advanced computer with 7" LCD blue Back-Lit screen.
- Display readouts : Time, Distance, RPM, Speed, Level, Calories, Pulse and Watts.
- 14 Programs, including 10 Manual, 2 HRC, 2 User set.

SPECIAL FEATURES

- Various seat height levels easily adjusted by knob ball while being seated.
- Ergonomic stationary handle bars with adjustable arm pads.
- Handheld pulse sensor.
- Adjustable pedal straps.
- 3 piece cranks.
- Transport wheels
- Built-in speakers & Ipad / MP3 auxillary jack.
- Ipad / Ipod charging station.
- High speed circulation fan that allows the user to stay cool during workout.
- Accessory tray, built-in reading rack.
- Adjustable floor levelers.
- Built-in receiver.
- Maximun User Weight : 180 Kgs.



KH1120

COMMERCIAL UPRIGHT BIKE



SPECIFICATIONS

- Dot matrix LED display showing Pulse, Recovery, Time, RPM, Speed, Distance, Calories, Watt, Heart Rate and Resistance.
- With self generator system.
- 12 programs : 4 HRC, 3 goal, 1 recovery and 4 user.
- Magnetic brake with V-belt drive system.
- 16 levels tension control system.
- With heart rate receiver.
- Hand grips with pulse sensors.
- Counter balance pedals.
- With bottle holder.
- PU seat with adjustable height.
- Transport wheels.
- User weight : 150 kg.



KH1020

COMMERCIAL UPRIGHT BIKE

SPECIFICATIONS

- LED display showing Pulse, Recovery, Time, RPM, Speed, Distance, Calories, Watt, Heart Rate and Resistance.
- With self generator system.
- 12 programs : 4 HRC, 3 goal, 1 recovery and 4 user.
- Magnetic brake with V-belt drive system.
- 16 levels tension control system.
- With heart rate receiver.
- Hand grips with pulse sensors.
- Counter balance pedals.
- With bottle holder.
- PU seat with adjustable height.
- Transport wheels.
- User weight : 140 kg.



KH815

LIGHT COMMERCIAL UPRIGHT BIKE

SPECIFICATIONS

- Auto scan advanced computer with blue BACK-LT LCD screen.
- 12 programs, including 1 manual, 2 HRC, 1 body fat, 2 user set.
- Display showing Pulse, Recovery, Time, RPM/Speed, Distance, K joule or Calories, Watt/Target Heart rate, Fat%, BMI, BMR, Body Type.
- Magnetic brake with V-belt drive system.
- 16 levels tension control system.
- With adapter power system.
- Innovative adjustment end cap, easy to go with uneven floor.
- Aluminum upright beam.
- Hand grip pulse sensors.
- Counter balance pedals.
- PU seat, seat height is adjustable.
- Hidden crank(3pcs) safer & neat.
- Transport wheels.
- Maximum user weight: 130 kg.



AB900

COMMERCIAL AIR BIKE

SPECIFICATIONS

- System : Fan drive.
- 1 manual + 12 built-in programs.
- Built-in wireless receiver.
- Transport wheels + Leverage adjustment.
- Big LCD with backlit.
- Quick buttons for interval program.
- Maximum user weight : 150 kg.



AB600

COMMERCIAL AIR BIKE

SPECIFICATIONS

- Heavy duty steel structure with 25" FAN.
- LCD monitor showing time, distance, speed, calories, watts, heart rate and interval settings.
- Transmission : Chain + V belt dry system.
- Handle with hand pulse.
- 4 way quick release seat adjustment.
- Universal ball joints provide stability and durability for long term workout.
- Transport wheels.
- Maximum user weight : 150 kg.



PULSE FITNESS

225G COMMERCIAL GROUP BIKE



The Pulse Group Cycle looks and performs magnificently. Built to give an effective workout and tough enough to cope with multiple classes, it is comfortable, durable and easy to maintain and adjust.

COLOUR CODED ADJUSTERS

To enable the rider to alter workout position for optimum safety, comfort and performance, users can easily and clearly adjust the Group Cycle handlebars, seat, pedal straps and resistance brake system. The Group Cycle also features adjustable feet for uneven gym floors.

SMOOTH FLY WHEEL

Uniquely designed to deliver a smooth, quiet and fluid motion for ultimate rider's comfort whilst providing operators a low maintenance solution.

INTEGRATED SWEAT GUARDS

Injection moulded sweat guards help protect key components of the Group Cycle from corrosion and rust ensuring the cycle is easy to maintain and stays cleaner for longer.

MAXIMUM USER WEIGHT : 180 KGS



KH3010

COMMERCIAL GROUP BIKE

SPECIFICATIONS

- Ultra sturdy structure with heavy duty crank.
- 21 kgs stainless steel fly wheel.
- Fully adjustable GEL seat with sweat proof finish.
- 4 way adjustable handle bar.
- Resistance Levels : Variable linear increase.
- Side break system.
- SPD racing pedals.
- Transport wheels for easy movement.
- Maximum user weight : 180 kg.



KH2010

COMMERCIAL GROUP BIKE

SPECIFICATIONS

- Sturdy structure with 20 kgs stainless steel fly wheel.
- Fully adjustable GEL seat with sweat proof finish.
- Adjustable and ergonomic handle bar assist the most comfortable sitting.
- Resistance Levels : Variable linear increase.
- Punch break system.
- SPD racing pedals.
- Transport wheels for easy movement.
- Maximum user weight : 150 kg.



KH1910

COMMERCIAL GROUP BIKE

SPECIFICATIONS

- New hardcore permanent magnetic control resistance system with 21 levels
- Dynamic & fashionable appearance with the overall streamlined design that brings new riding feeling
- Flywheel post position is similar with the rear drive of bicycle that enhances the training effect with riding posture
- The rear flywheel can prevent sweat spattering on the flywheel during training and prolongs the life of the bicycle
- Compared with the traditional spinning bike, covered rear flywheel can effectively protect the knee from injury and ensure safety while riding
- Advanced ergo - formed handle bars that provides comfortable riding posture.
- Light & easy to move
- Maximum user weight : 150 kg



KH1710

COMMERCIAL GROUP BIKE

SPECIFICATIONS

- Ultra sturdy PATENTED design.
- New fully covered design making it sweat proof.
- Adjustable seat and handle.
- High quality ribbed belt with tension wheel driving system.
- Press type braking system.
- Maximum user weight : 150 kg.



KH153

LIGHT COMMERCIAL GROUP BIKE

SPECIFICATIONS

- Adjustable resistance.
- Dipping handle bar.
- With 20kgs flywheel.
- With adjustable seat.
- Computer functions : time, speed, distance, calories & pulse.
- Maximum User Weight 140 Kgs.



E520

COMMERCIAL FLUID ROWER



SPECIFICATIONS

- Full commercial machine designed for heavy duty service. 20 Level Patented Variable Fluid Resistance Absolute Comfort, Stability & Performance with Widest Range of Resistance Available.
- Height Adjustable footplates with Advanced Heel Cradle footboard design (Reg. Design) and straps to ensure optimal foot placement and comfortable rowing position.
- Compact side mounted tank design delivers ease of adjustment.
- Interactive Performance Monitor (IPM) with USB port: The IPM displays: time; speed; distance; stroke rate; calories per hour; watts; 20 level adjustment, pacer, and has a heart rate receiver built in. The IPM gives you quick start, manual programs, interval training, USB port allows interactive programming.
- Fitted with Heart Rate sensor as standard compatible with all main HR belts.
- 6 previous workout memories and a unique pacer system.
- Unmatched Durability - Virtually Maintenance Free.
- Strikingly attractive blue polycarbonate tank with contrasting seal.
- Deluxe ergonomic handle allows comfortable grip and minimised strain on forearms, wrists and hands.
- Low noise Belt Drive - No Chains to lubricate.
- World's Most Comfortable Seat at "Office Chair" Height. Optional Back Support (Not Included). May be purchased separately to add lumbar support to the rower.
- Concealed Air-Glide Seat Rollers for safer and cleaner continuous smooth operation.
- Rubber feet for adhesion to floor surfaces and to prevent damage.
- Rubber dipped retainer for damage free handle stowage when not in use.
- "Easy roll" transport wheels.
- Unique rugged heel support assembly.
- Maximum user weight 204kg (450lbs). Dimensions: 190 x 71 cm (75 x 28") in use. Stands for compact storage.



FIRST DEGREE FITNESS
FLUID INNOVATION

www.firstdegreefitness.com

AR900

VIVA '2' COMMERCIAL AIR ROWING MACHINE

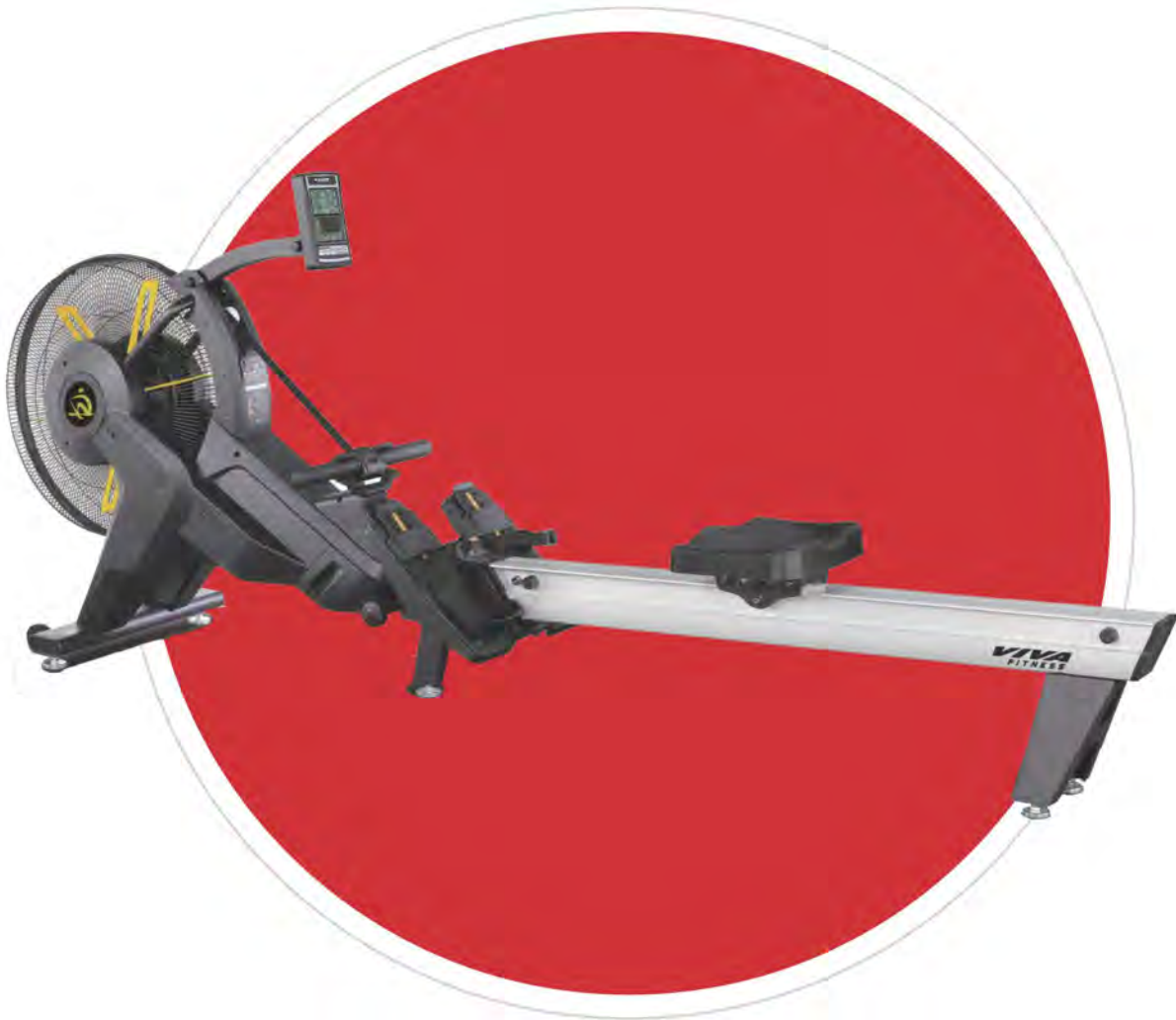

SPECIFICATIONS

- System: FAN drive + Eddy Current.
- Resistance level : 12 levels.
- Resistance control on Knob adjustment.
- Built-in Wireless receiver.
- Transport wheels + Leverage adjustment.
- Single Aluminum Extrusion.
- LCD with Backlit.
- Max. user Weight 160 kgs.



AR700

COMMERCIAL AIR ROWER

SPECIFICATIONS

- Solid steel frame that folds up for easy storage.
- Air generated 10 levels resistance.
- High strength steel chain rowing strap for a smooth and quiet pull.
- Back-lit bright LCD monitor that displays all workout data.
- High quality contoured seat.
- Adjustable footrest with numbered setting
- Max. user weight: 160 Kgs.



AR800

COMMERCIAL AIR ROWER

SPECIFICATIONS

- Dual Technology - resistance with both magnetic and air.
- High strength nylon rowing strap for a smooth and quiet pull.
- Back-lit LCD monitor, complete with 12 pre-programmed rowing routines.
- High quality contoured seat.
- Aluminum rowing beam for a smooth rowing motion.
- 8 resistance level.
- Assembled Dimension: 223 x 51 x 103 cm.
- Max. user weight: 150 Kgs.



SKI 2

SKI MACHINE

SPECIFICATIONS

- Durable and ergonomic construction.
- Can be either mounted on a wall or with specially designed anti-skid floor stand.
- Air generated 10 levels resistance.
- High strength light weight drive cord with strapless handles for secure grip.
- Back-lit bright LCD monitor that displays all workout data.
- Max. user weight: 160 Kgs.



TYRE FLIP

BY ABS CO USA

SPECIFICATIONS

- Starting resistance of 100 lbs.
- Plate loaded ability up to 40 additional pounds.
- 4 sounds reducing bumpers.
- 2 battle rope anchor points.
- 4 floor levelers..
- 8 floor mounting points.
- Extended warranty.
- Dimensions : 4' x 5'
- Weight : 293 lbs.

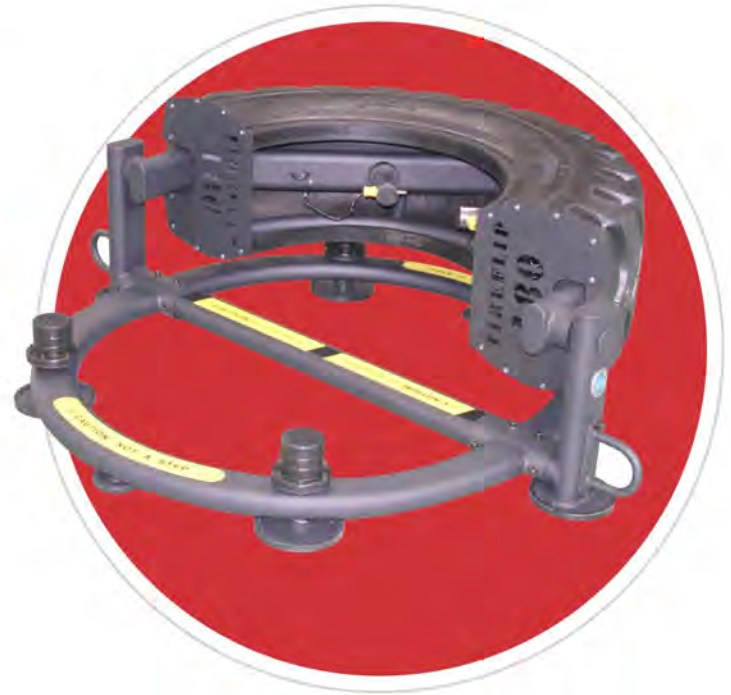

TYRE FLIP

180

SPECIFICATIONS

- Starting resistance of 100 lbs.
- Plate loaded ability up to 40 additional pounds.
- 4 sounds reducing bumpers .
- 2 battle rope anchor points.
- 4 floor levelers.
- 8 floor mounting points.
- Weight of the tyre : 49 kgs.
- Weight of the machine : 145 kgs.



KH777

COMMERCIAL VIBRATOR

SPECIFICATIONS

- AC driving system with adjustable variable frequency.
- AC Motor power : 500W with **SPIRIL MOVEMENT**.
- Speed range : 60 levels.
- Large LCD panel.
- Built in speakers & MP3 axillary jack / USB slot.
- Various motivating programs for different workout requirements
- Exercise charts showing posture for different body parts.
- With straps for stretching exercises.
- Maximum User Weight : 180 Kgs



INFINITY

TRAINER

SPECIFICATIONS

- Unique machine with variety of exercises possible.
- Heavy duty stainless steel base.
- Dimensions : 220x135x162 cms
- Weight : 160 kgs



KH6060 STEPMILL

Durable peddle and chain design



Smart quick & program keys



Easy reach handle bar



Powerful 2 HP AC motor drive system



SPECIFICATIONS

- Console : LED dot-matrix display.
- Data readout : Level, calories, time, distance, speed etc.
- Program : Calories goal, marathon, random, hill, speed interval, fat burn, cardio, fitness training 5k / 10k, interval heart rate control, Intensive heart rate & manual.
- With water bottle holder & accessories tray.
- SPM level : 20 levels.
- With USB charging port.
- With O² generator.
- Max user weight : 180 kgs.



KH5050 STEPMILL



Big comfortable paddles



Powerful 3 HP AC motor drive system



SPECIFICATIONS

- Console : LED dot-matrix display.
- Data readout : Level, calories, time, distance, speed etc.
- Program : Various motivating programs for different workout requirements.
- Max user weight : 150 kgs.



GYM / CROSSFIT FAN



SPECIFICATIONS

SERIOUS AIRFLOW
Creates airflow that spans one-third the length of a football field (36.6 meters!) Could covers a area 500 m² maximum.

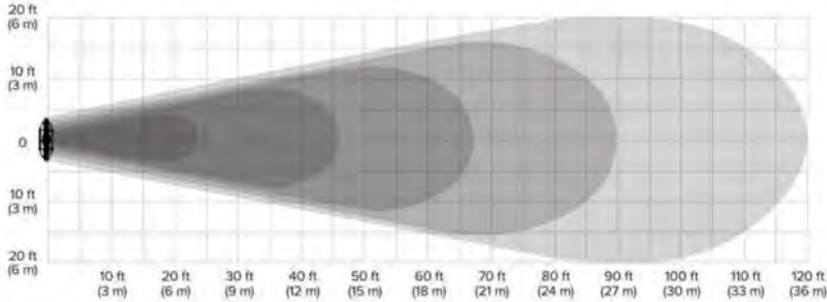

- 1) QUIET & EFFICIENT**
Gearless direct-drive motor draws electricity only 0.5~0.7 KW Per hour (that's less power than a toaster).
Quiet enough to hold a conversation right next to the fan.
- 2) INFINITE SPEED CONTROL**
Variable speed controller offers maximum 200Turns/Min fully-adjustable airflow.
- 3) PETITE**
Stands just under 2.1m tall
Fits through standard interior doors.
- 4) EASY TO USE, EASY TO MOVE**
Arrives pre-assembled—just roll it off the pallet and go.
Comes standard with strong wheels.
Includes handles on both sides for easy maneuvering.
Plugs into any standard 220V power supply.
5 Meters power cord extends FAN reach.
- 5) SMASHINGLY DURABLE**
Steel cage and Aluminum airfoils can handle the toughest environments.
- 6) PRODUCT SIZE & WEIGHT**
2.1mX0.75mX2.12m
200 KG

DUAL STRENGTH RANGE



pulse
fitness UK

300H

Chest / Shoulder Press

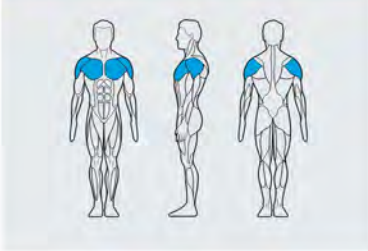

Length	1690 mm	Width	1310 mm
Height	1580 mm	Weight	143 kg

Max User Weight	180 kg
Weight Stack	100 kg



Instructional placards



Aluminium touch points



Low profile weight stack



315H

Pec Fly / Rear Delt

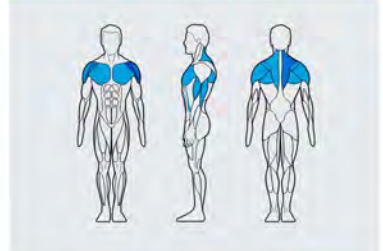

Length	1370 mm	Width	1501 mm
Height	1948 mm	Weight	157 kg

Max User Weight	180 kg
Weight Stack	100 kg



Instructional placards



Aluminium touch points



Low profile weight stack

320H

Dip / Chin Assist

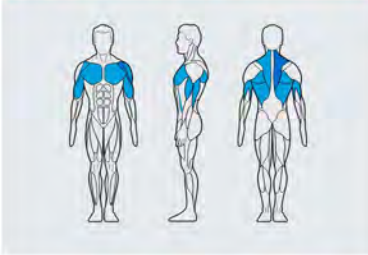

Length	1164 mm	Width	1543 mm
Height	2200 mm	Weight	153 kg

Max User Weight	180 kg
Weight Stack	77 kg



Instructional placards



Aluminium touch points



Low profile weight stack

375H

Pulldown / Seated Row

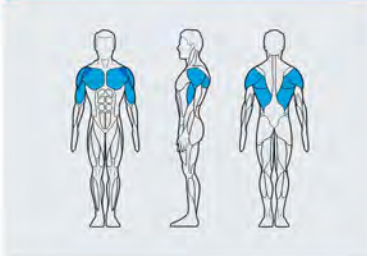

Length	1875 mm	Width	1214 mm
Height	2251 mm	Weight	148 kg

Max User Weight	180 kg
Weight Stack	86 kg



Instructional placards



Aluminium touch points



Low profile weight stack



555H

Leg Extension / Curl

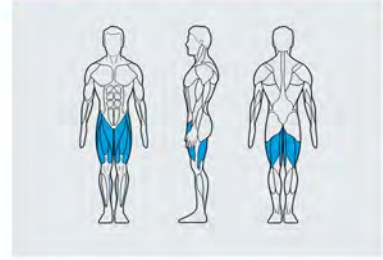

Length	1610 mm	Width	1328 mm
Height	1580 mm	Weight	164 kg

Max User Weight	180 kg
Weight Stack	132 kg



Instructional placards



Aluminium touch points



Low profile weight stack

575H

Leg Press / Calf Ext

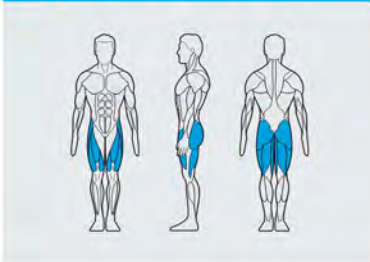

Length	2025 mm	Width	1149 mm
Height	1580 mm	Weight	175 kg

Max User Weight	180 kg
Weight Stack	132 kg



Instructional placards



Aluminium touch points



Low profile weight stack



Instructional placards



Aluminium touch points



Low profile weight stack



360H

Bicep Curl / Tricep Ext

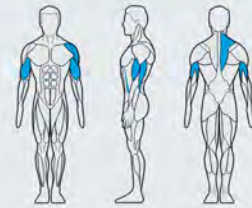

Length	1115 mm	Width	1310 mm
Height	1580 mm	Weight	110 kg

Max User Weight	180 kg
Weight Stack	90 kg

525H

Deep Squat / Standing Leg Extension

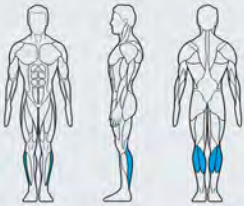

Length	1295 mm	Width	1154 mm
Height	1580 mm	Weight	147 kg

Max User Weight	180 kg
Weight Stack	113 kg



Instructional placards



Aluminium touch points



Low profile weight stack



Instructional placards



Aluminium touch points

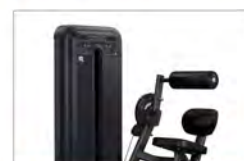

Low profile weight stack



595H

Abdominal / Back Ext

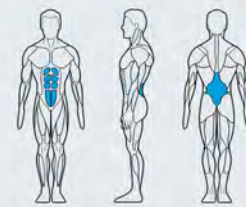

Length	1120 mm	Width	1250 mm
Height	1580 mm	Weight	135 kg

Max User Weight	180 kg
Weight Stack	118 kg

IT SERIES UNIQUE FEATURES

✦ Long lasting upholstery - 20mm thick plywood backing followed by 40mm thick foam core covered by industrial vinyl

✦ Aircraft spec 5mm American LOOS cable with 4,200 lb breaking strength. All fittings tested for 250,000 cycles using full weight stack

✦ Easy-to-use seat with minimal adjustments and pre-stretched features for optimal exercise positions



✦ 3mm thick, 50mm by 100 mm racetrack tubing, electro-welded for maximum strength
✦ Electrostatic powder coated and heat cured paint finish for maximum durability

✦ Compact - space efficient design requires minimal floor space
✦ Rubber grip prevent from being slipped

IT9501

CHEST PRESS

- LXWXH : 148X120X150 CM
- Weight Stack : 200 lbs

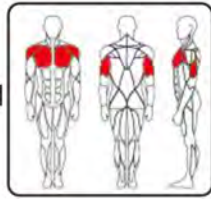

IT9502

LAT PULLDOWN

- LXWXH : 143X138X188 CM
- Weight Stack : 295 lbs

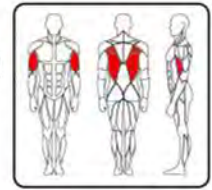

IT9503

ARM CURL

- LXWXH : 130X121X150 CM
- Weight Stack : 160 lbs

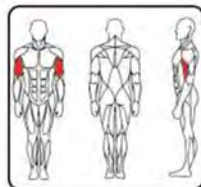

IT9505

LEG EXTENSION

- LXWXH : 154X119X150 CM
- Weight Stack : 200 lbs

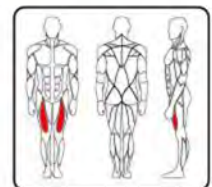

IT9506

SEATED LEG CURL

- LXWXH : 147X120X150 CM
- Weight Stack : 200 lbs

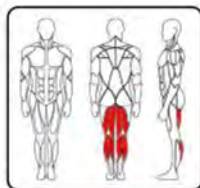

IT9508

ABDUCTOR / ADDUCTOR

- LXWXH : 155X90X150 CM
- Weight Stack : 160 lbs

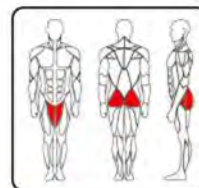

IT9510

LEG PRESS

- LXWXH : 180X120X150 CM
- Weight Stack : 295 lbs

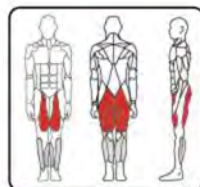

IT9512

SHOULDER PRESS

- LXWXH : 156X144X151 CM
- Weight Stack : 200 lbs

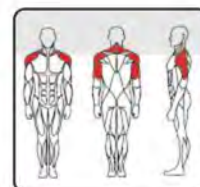

IT9514

ABDOMINAL

- LXWXH : 135X115X158 CM
- Weight Stack : 200 lbs

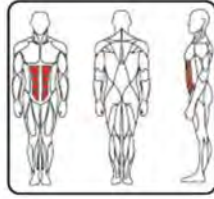

IT9515

PEC FLY / REAR DELT

- LXWXH : 166X129X200 CM
- Weight Stack : 200 lbs

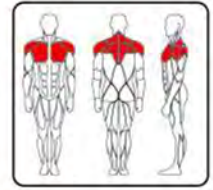

IT9516

STANDING CALF

- LXWXH : 135X115X158 CM
- Weight Stack : 235 lbs

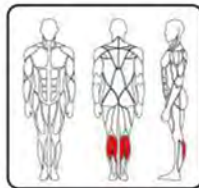

IT9518

ROTARY TORSO

- LXWXH : 122X120X150 CM
- Weight Stack : 160 lbs

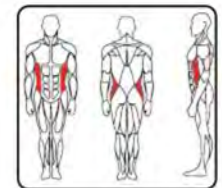

IT9519

VERTICAL ROW

- LXWXH : 144X114X150 CM
- Weight Stack : 200 lbs

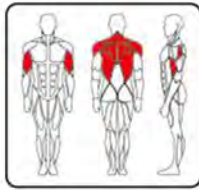

IT9520

DIP / CHIN ASSIST

- LXWXH : 122X136X220 CM
- Weight Stack : 200 lbs

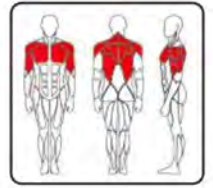

IT9521

PRONE LEG CURL

- LXWXH : 147X120X150 CM
- Weight Stack : 200 lbs

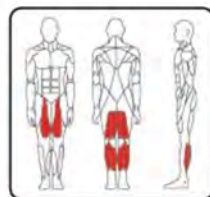

IT9522

LAT PULL / SEATED ROW

- LXWXH : 135X115X158 CM
- Weight Stack : 295 lbs

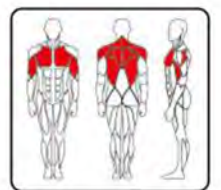

IT9526

GLUTE

- LXWXH : 150X124X150 CM
- Weight Stack : 200 lbs

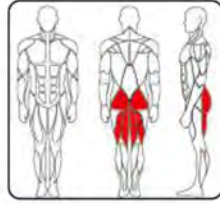

IT9528

LEG EXTENSION / LEG CURL

- LXWXH : 135X122.7X150.6 CM
- Weight Stack : 295 lbs

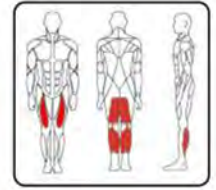

IT9529

MULTI PRESS

- LXWXH : 182.7X143.7X166.7 CM
- Weight Stack : 235 lbs

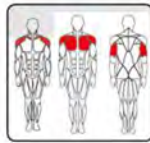

IT9533

BICEP CURL / TRICEP EXTENSION

- LXWXH : 130X124X150.6 CM
- Weight Stack : 200 lbs

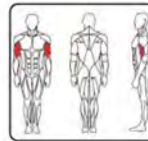

IT9534

BACK EXTENSION / ABDOMINAL

- LXWXH : 119.6X118.9X150.6 CM
- Weight Stack : 200 lbs

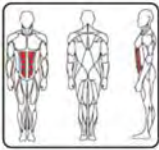

IT9302

LAT PULLDOWN

- LXWXH : 145X127X198 CM.
- Weight stack : 275 LBS.



IT9303

ARM CURL

- LXWXH : 137X117X148.5 CM.
- Weight stack : 150 LBS.



IT9304

PECTORAL

- LXWXH : 109X153X148.5 CM.
- Weight stack : 200 LBS.



IT9305

LEG EXTENSION

- LXWXH : 142X113X148.5 CM.
- Weight stack : 200 LBS.



IT9306

SEATED LEG CURL

- LXWXH : 174.4X112.7X148.5 CM.
- Weight stack : 200 LBS.



IT9328

LEG EXTENSION / LEG CURL

- LXWXH : 148X120.5X149 CM.
- Weight Stack : 200 LBS.



IT9308

ABDUCTOR & ADDUCTOR

- LXWXH : 80.5X173X148.5 CM.
- Weight stack : 150 LBS.



IT9309

ROTARY HIP

- LXWXH : 100X129X148.5 CM.
- Weight stack : 200 LBS.



IT9310 LEGPRESS

- LXWXH : 206X112X148.5 CM.
- Weight stack : 300 LBS.



IT9312 SHOULDER PRESS

- LXWXH : 194X147X148.5 CM.
- Weight stack : 200 LBS.



IT9314 ABDOMINAL

- LXWXH : 136X105X148.5 CM.
- Weight stack : 200 LBS.



IT9315 PEC FLY / REAR DELT

- LXWXH : 166X129X200 CM.
- Weight stack : 200 LBS.

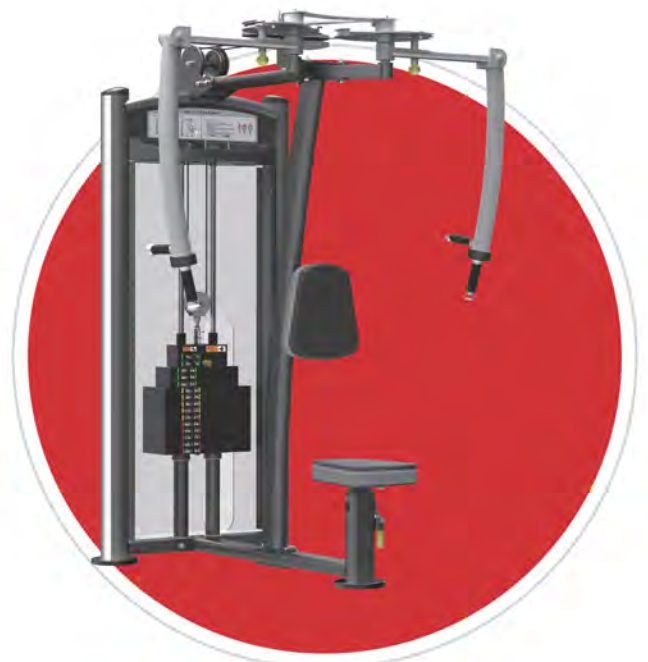

IT9317

TRICEP

- LxWxH 163.8x114x148.5 cm.
- Weight stack: 200 LBS.



IT9318

ROTARY TORSO

- LXWXH : 118X121X148.5 CM.
- Weight stack : 150 LBS.

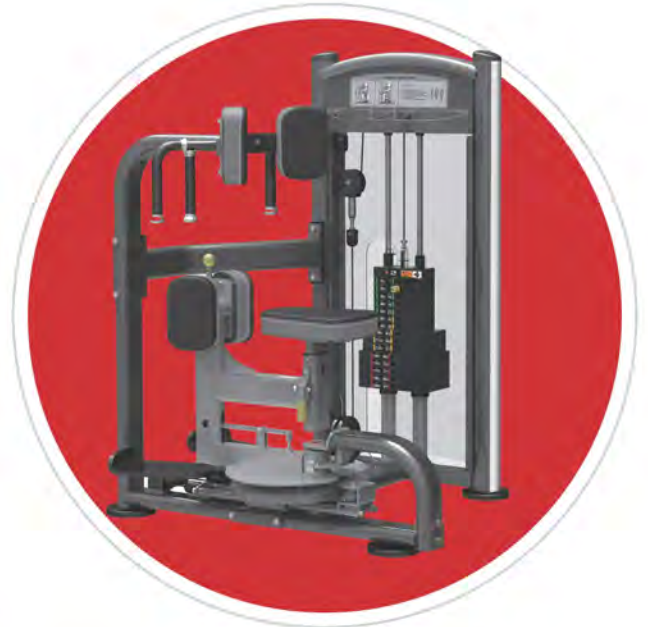

IT9319

VERTICAL ROW

- LXWXH : 158X109X148.5 CM.
- Weight stack : 200 LBS.



IT9320

DIP / CHIN ASSIST

- LXWXH : 122X136X220 CM.
- Weight stack : 200 LBS.



IT9321

PRONE LEG CURL

- LXWXH : 178.7X113.6X148.5 CM.
- Weight stack : 200 LBS.



IT9322

LAT PULL / SEATED ROW

- LXWXH : 122X185X220 CM.
- Weight stack: 275 LBS.



IT9324

LATERAL RAISE

- LXWXH : 119.5X94X148.5 CM.
- Weight stack : 200 LBS.



IT9325

ADJUSTABLE HI/LO PULLEY

- LXWXH : 122X185X220 CM.
- Weight stack: 275 LBS.

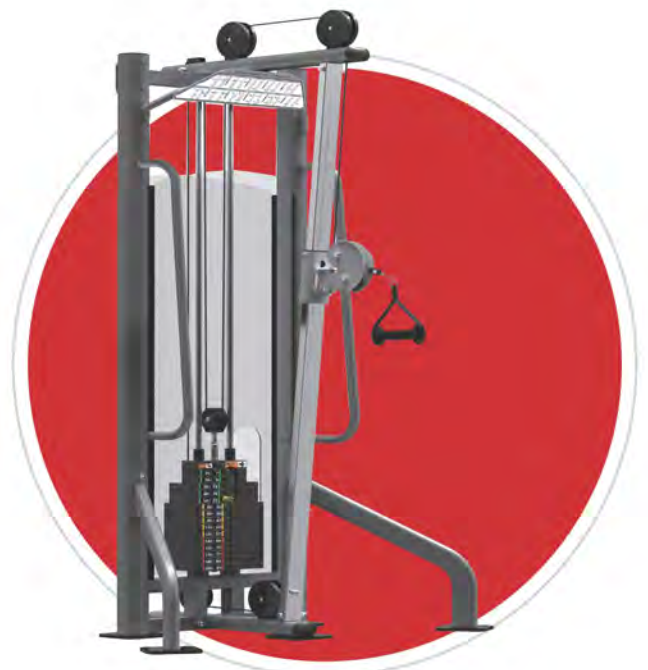

IT9313

CABLE CROSSOVER

- LXWXH : 386X100X236 CM.
- Weight stack : 200 LBS X 2.

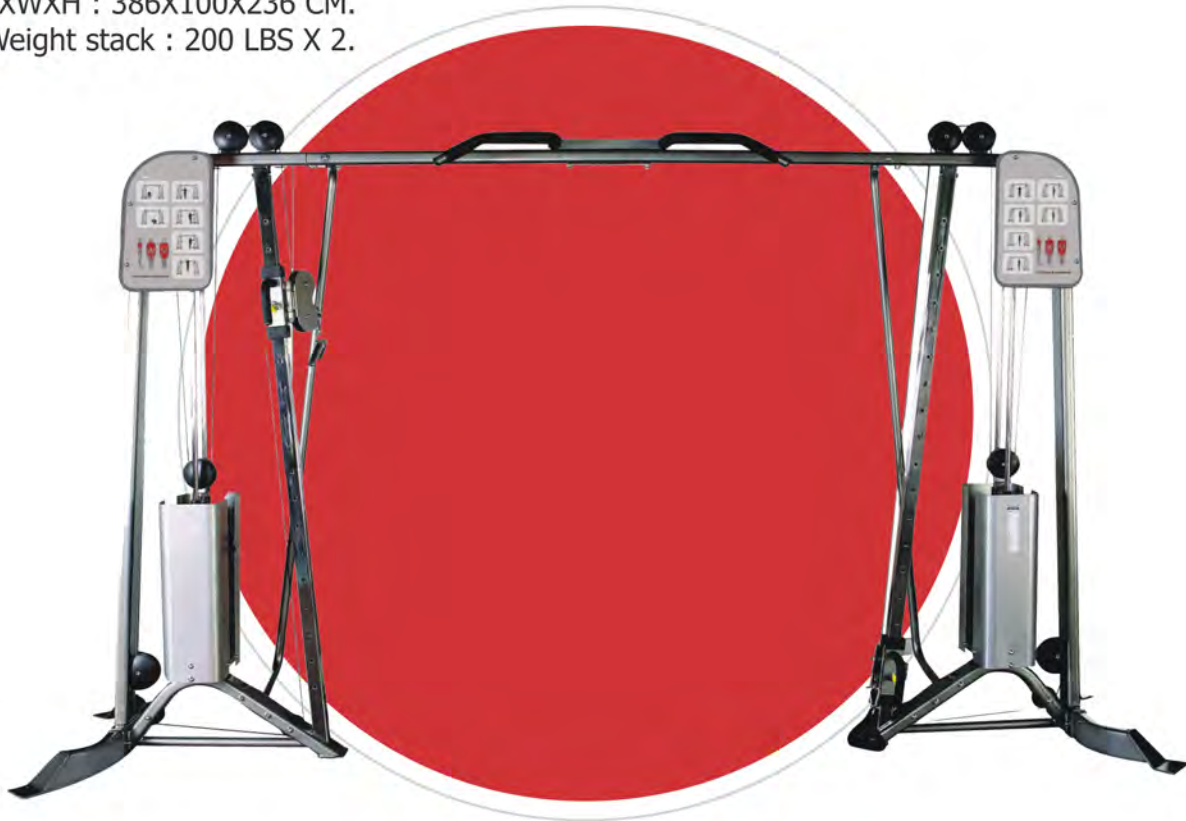

IT9330

FUNCTIONAL TRAINER

- LXWXH : 150X146X218 CM.
- Weight stack : 200 LBS X 2.
- 34 different exercises (Chart included).



IT9327

4 STACK MULTI-STATION

- LXWXH : 335x209x232.9 cm.
- Weight stack: 275 LBS X 4.

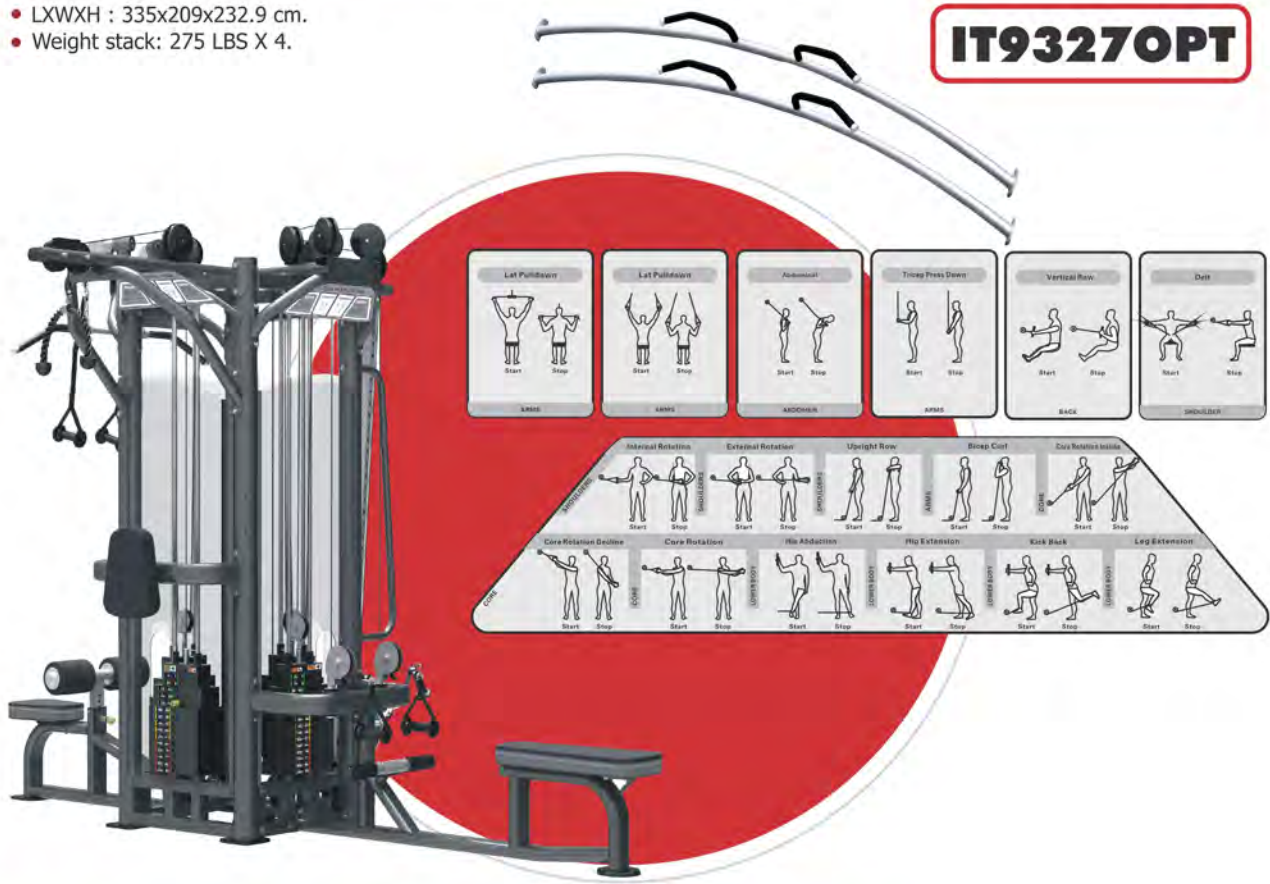

IT9325+IT9327OPT+IT9325

DELUXE CABLE CROSSOVER

- Weight stack: 275 LBS X 2.

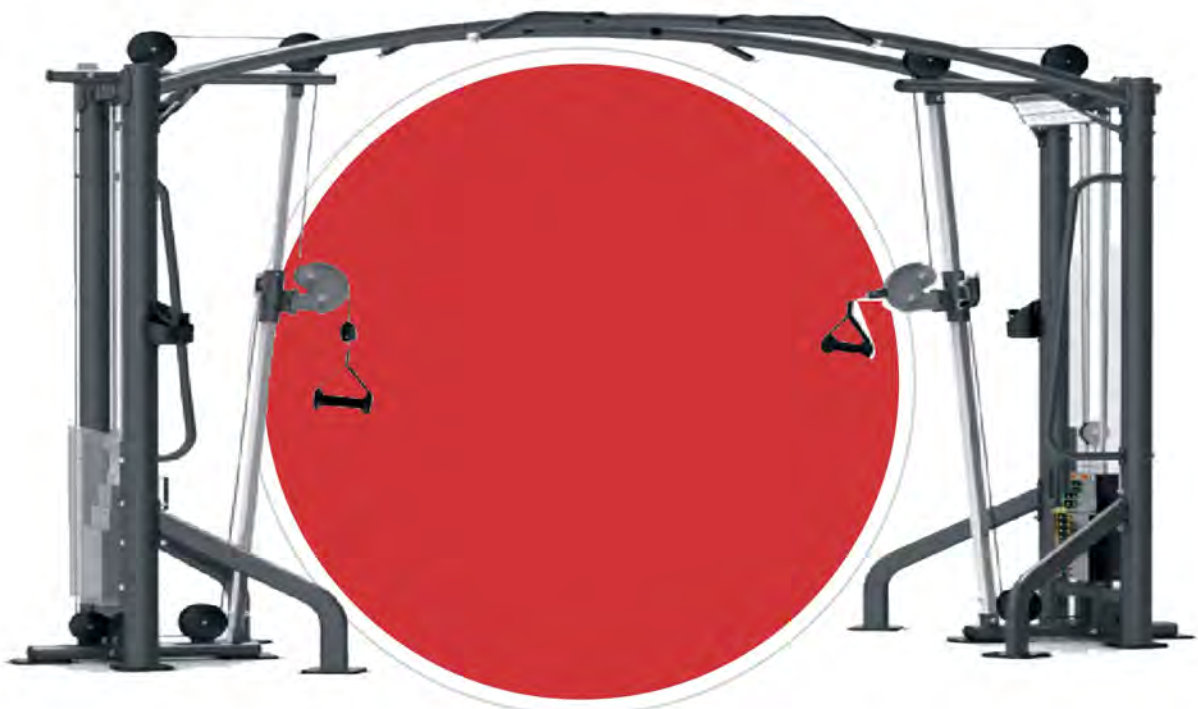

IT9325+IT9327OPT+IT9327

5 STATION MULTI GYM

- Weight stack: 275 LBS X 5.

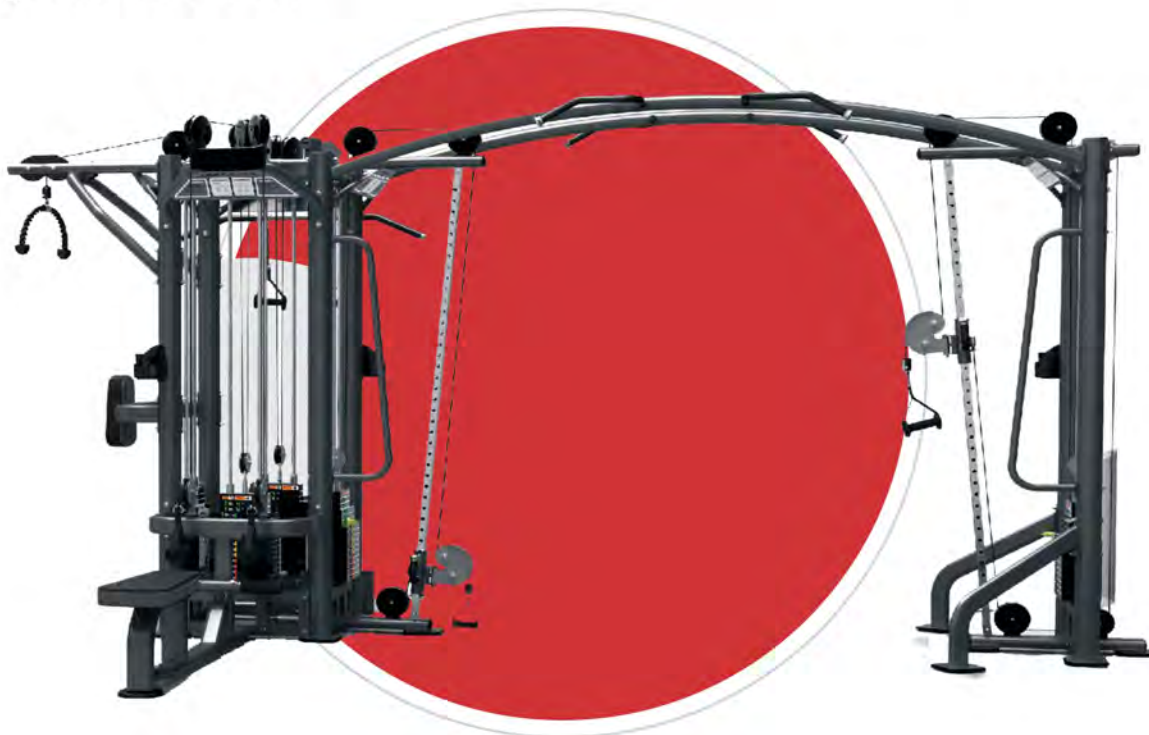

IT9327+IT9327OPT+IT9327

8 STATION MULTI GYM

- Weight stack: 275 LBS X 8.

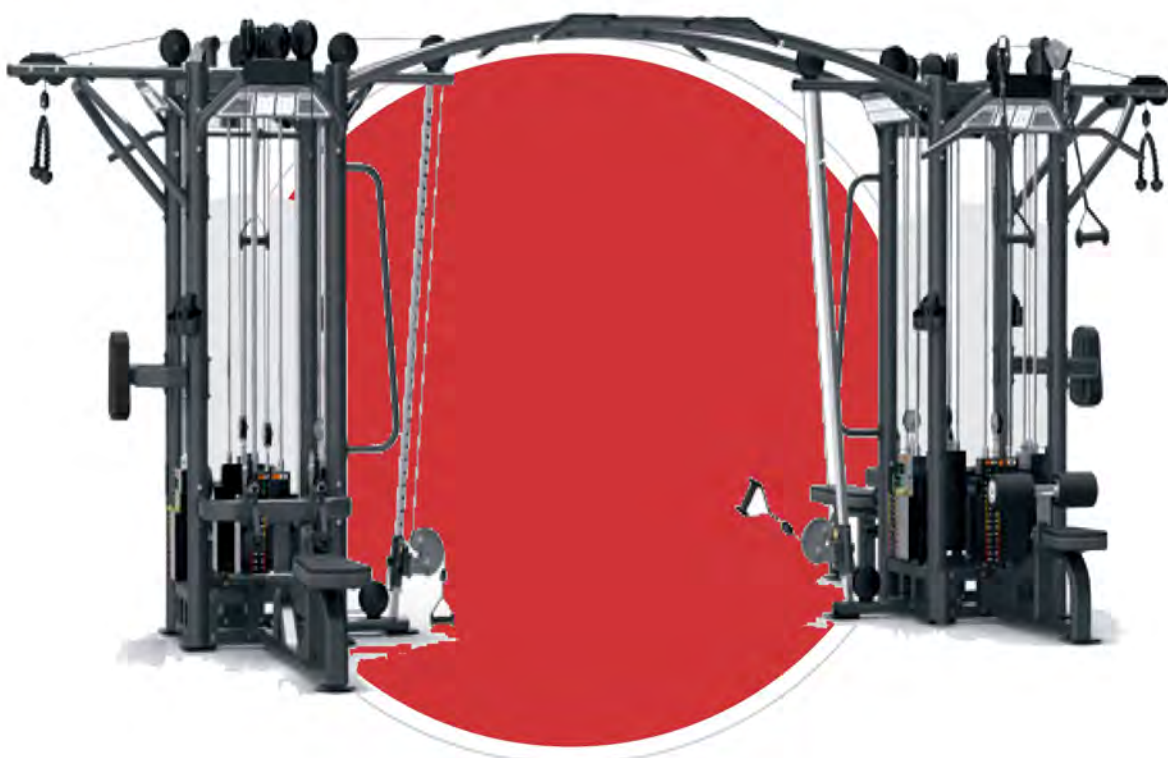

IT9326

GLUTE MASTER

- LXWXH : 107X105.3X148.5 CM.
- Weight stack : 200 LBS.



IT9331

CHEST PRESS

- LXWXH : 149.4X135.6X182.6 CM.
- Weight stack : 200 LBS.



IT9332

BACK EXTENSION

- LXWXH : 118.5x98.3x148.5 CM.
- Weight stack: 200 LBS.



IT7001

COUNTER BALANCED SMITH MACHINE

- LXWXH : 138X225X229 CM.



IT7002

SEATED PREACHER CURL

- LXWXH : 101X81X88 CM.



IT7003

AB BENCH

- LXWXH : 174.5X93.6X99.7 CM.



IT7004

STRETCH

- LXWXH : 128.8X55.5X90 CM.



IT7005

SEATED CALF RAISE

• LXWXH : 135.6X75.1X83.1 CM.



IT7006

45° LEG PRESS / HACK SQUAT

• LXWXH : 225.3X97.5X147.5 CM.



IT7007

MULTI
HYPER EXTENSION

• LXWXH : 121.1X72.5X93.3 CM.



IT7009

FLAT BENCH

• LXWXH : 115.9X90X42 CM.



IT7010

VERTICAL KNEE RAISE / IP STAND

• LXWXH : 112X78X155 CM.

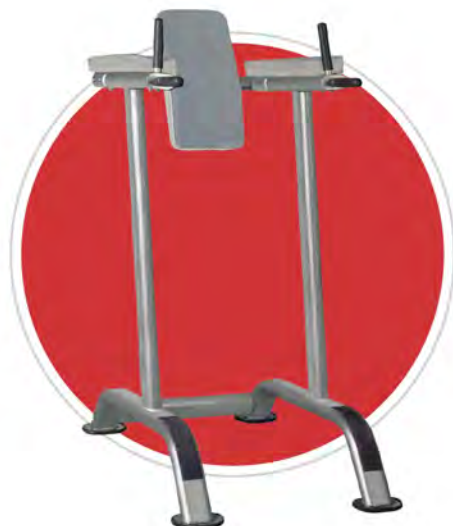

IT7011

MULTI ADJUSTABLE
BENCH

- LXWXH : 121X75X46.5 CM.



IT7012

12 PAIRS
DUMBBELL RACK

- LXWXH : 159X81.5X98.5 CM.



IT7013

MULTI AB BENCH

- LXWXH : 173.8X72.5X89.9 CM.



IT7014

OLYMPIC FLAT BENCH

- LXWXH : 170X166X137 CM.



IT7015

OLYMPIC INCLINE BENCH

- LXWXH : 163.2X165.8X137.3 CM.



IT7016

OLYMPIC DECLINE BENCH

- LXWXH : 210.3X165.8X137 CM.

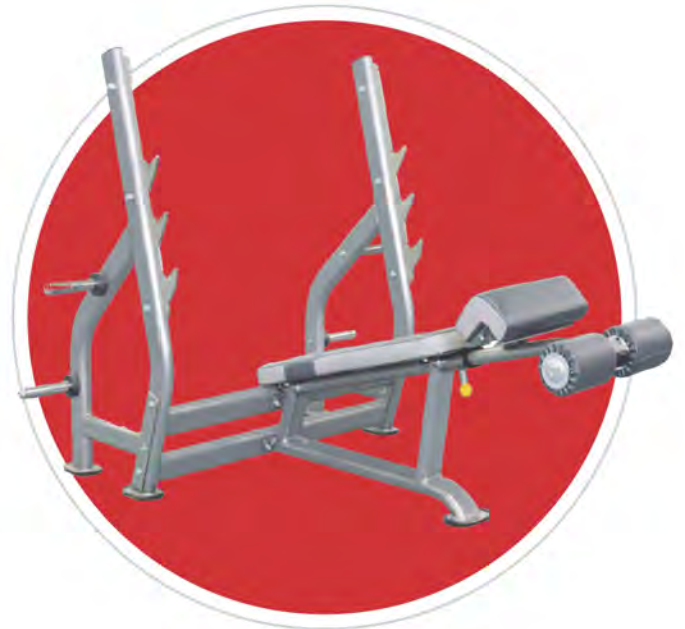

IT7017

OLYMPIC WEIGHT TREE

- LXWXH : 96X62.5X120 CM.



IT7018

DUMBBELL RACK

- LXWXH : 158X81.4X198 CM.

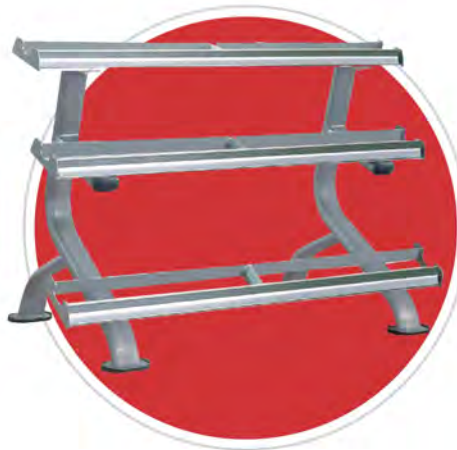

IT7019

PLATE LOADED T-BAR ROW

- LXWXH : 198X98X126 CM.



IT7022

UTILITY BENCH



IT7031

SHOULDER PRESS BENCH



IT7032

BARBELL RACK



• LXWXH : 134.9X112.6X165 CM.

• LXWXH : 96X71X1086 CM.

IT7033

MAX RACK

• LXWXH : 96X71X108 CM.



PL9002

LAT PULLDOWN /
SEATED ROW

- LXWXH : 176.4X101.9X219.2 CM.
- Weight stack : 250 LBS.



PL9010

LEG / CALF PRESS

- LXWXH : 191X113X152 CM.
- Weight stack : 250 LBS.



PL9016

HIP ABDUCTOR / ADDUCTOR

- LXWXH : 159X71X152 CM.
- Weight stack : 250 LBS.



PL9019

LEG EXTENSION / LEG CURL

- LXWXH : 123X122X152 CM.
- Weight stack : 250 LBS.



PL9021

MULTI PRESS

- LXWXH : 203.3X131.6X152 CM.
- Weight stack : 250 LBS.



PL9022

PEC FLY / REAR DELT

- LXWXH : 136.5X127.8X206 CM.
- Weight stack : 250 LBS.



PL9023

BICEPS / TRICEPS

- LXWXH : 108X120X152 CM.
- Weight stack : 250 LBS.



PL9024

AB / LOW BACK

- LXWXH : 101X110X152 CM.
- Weight stack : 250 LBS.



BS SERIES UNIQUE FEATURES

✦ Long lasting upholstery - 20mm thick plywood backing followed by 40mm thick foam core covered by industrial vinyl

✦ Non absorbing PVC compound retained with aluminum collars

✦ Black painted steel weight plates with self aligning low friction sleeves
✦ Magnetic color coded pin with coiled lanyard
✦ 5mm coated steel cable for smooth and secure performance
✦ Glass fiber reinforced nylon pulleys with deep V-groove that provides secured cable positioning and fluid bearing rotation



✦ 60mm x 120mm Heavy guage flat oval steel tubing
✦ Electrostatic powder coated and heat cured paint finish for maximum durability

✦ Compact - space efficient design requires minimal floor space
✦ Rubber grip prevent from being slipped

BS008

LEG CURL/EXTENSION

- LXWXH : 131.7X137.8X153 CM.
- Weight stack : 220 LBS.



BS009

MULTI PRESS

- LXWXH : 197.2X152.9X153 CM.
- Weight stack : 220 LBS.



BS010

PULL DOWN/MID ROW

- LXWXH : 196.8X151.6X211 CM.
- Weight stack : 220 LBS.



BS012

BICEPS CURL/TRICEPS PRESS

- LXWXH : 137.9X114.6X153 CM.
- Weight stack : 220 LBS.



BS013

ABDOMINAL/BACK EXTENSION

- LXWXH : 131.7X137.8X153 CM.
- Weight stack : 220 LBS.



BS011

PEC FLY/REAR DELT

- LXWXH : 179X114.1X202 CM.
- Weight stack : 220 LBS.



BS015

LEG PRESS/CALF RAISE

- LXWXH : 186.5X118.3X153 CM.
- Weight stack : 220 LBS.



BS016

HIP ABDUCTION/ADDUCTION

- LXWXH : 157.3X94X153 CM.
- Weight stack : 220 LBS.



BS017

DIP / CHIN ASSIST

- LXWXH : 188X123.3X215.3 CM.
- Weight stack : 220 LBS.



BEAST SERIES UNIQUE FEATURES

✦ Instructive - simple, step-by-step instructions and training tips help users get the most out of their exercise. Makes exercise easy and enjoyable

✦ Aesthetic looking bottle holder located at a convenient height.

✦ Strong ABS cover for user safety and machine protection.

✦ Newly designed state of art frame to give ultimate strength to the machine.
✦ Tubing: 3mm, 50mm by 100mm race track tubing, electro-welded to maximum integrity.
✦ Color: metallic silver gray
✦ Finish: Powder-coated painting color for premium look and also for protection from rusting.

✦ Seats made from integrated foam to give perfect support and avoid de-shaping even after long use.

✦ Easy-to-use, minimal adjustments and pre-stretch features allow for optimal exercise positions.
✦ Made from stainless tube to avoid rusting.

✦ Aircraft spec 5mm American LOOS cable with a 3,500 lbs breaking strength. End fittings tested to 200,000 cycles using full weight stack.
✦ Pure steel weight stacks.
✦ D: 106.2mm powerful nylon pulley in full alignment with cable for lifetime use.

✦ Compact - space efficient design requires minimal floor space.
✦ Rubber grip prevent from being slipped.

BEAST 1

CHEST PRESS

- WITH COUNTER
- WEIGHT STACK : 200 LBS



BEAST 2

SHOULDER PRESS

- WITH COUNTER
- WEIGHT STACK : 200 LBS



BEAST 3

INDEPENDENT ARM

- WITH COUNTER
- WEIGHT STACK : 175 LBS



BEAST 4

TRICEP PRESS

- WITH COUNTER
- WEIGHT STACK : 175 LBS



BEAST 5

MULTI PRESS

- WITH COUNTER
- WEIGHT STACK : 200 LBS



BEAST 6

PEC FLY / REAR DELT

- WITH COUNTER
- WEIGHT STACK : 200 LBS



BEAST 7

LAT PULL / SEATED ROW

- WITH COUNTER
- WEIGHT STACK : 220 LBS



BEAST 8

LOW ROW

- WITH COUNTER
- WEIGHT STACK : 175 LBS



BEAST 9

ASSISTED CHIN DIP

- WITH COUNTER
- WEIGHT STACK : 200 LBS



BEAST 10

ABDOMINAL

- WITH COUNTER
- WEIGHT STACK : 175 LBS



BEAST 11

ABDUCTOR / ADDUCTOR

- WITH COUNTER
- WEIGHT STACK : 175 LBS



BEAST 12

SEATED LEG CURL

- WITH COUNTER
- WEIGHT STACK : 175 LBS



BEAST 13

PRONE LEG CURL

- WITH COUNTER
- WEIGHT STACK : 200 LBS



BEAST 14

LEG EXTENSION

- WITH COUNTER
- WEIGHT STACK : 200 LBS



BEAST 15

LEG CURL / LEG EXTENSION

- WITH COUNTER
- WEIGHT STACK : 200 LBS



BEAST 16

LEG PRESS

- WITH COUNTER
- WEIGHT STACK : 220 LBS



BEAST 19

CABLE CROSSOVER

- WEIGHT STACK : 200x2 LBS

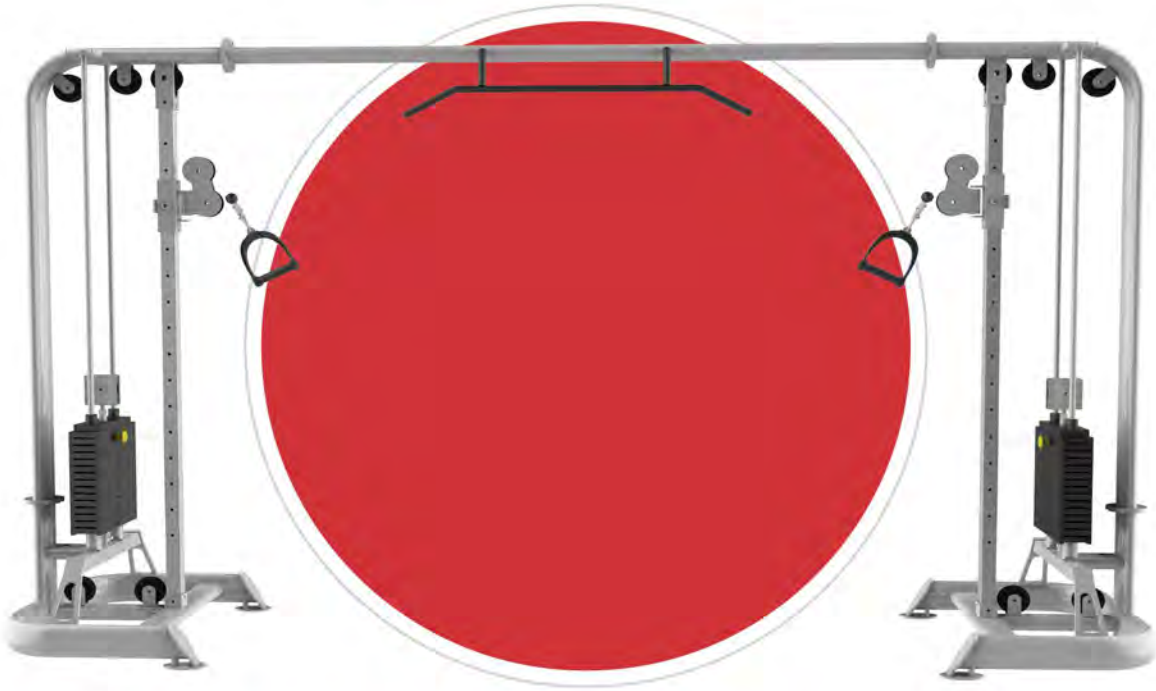

BEAST 18

SMITH MACHINE

- COUNTER BALANCED



BEAST 20

FUNCTIONAL TRAINER

- WEIGHT STACK : 200x2 LBS

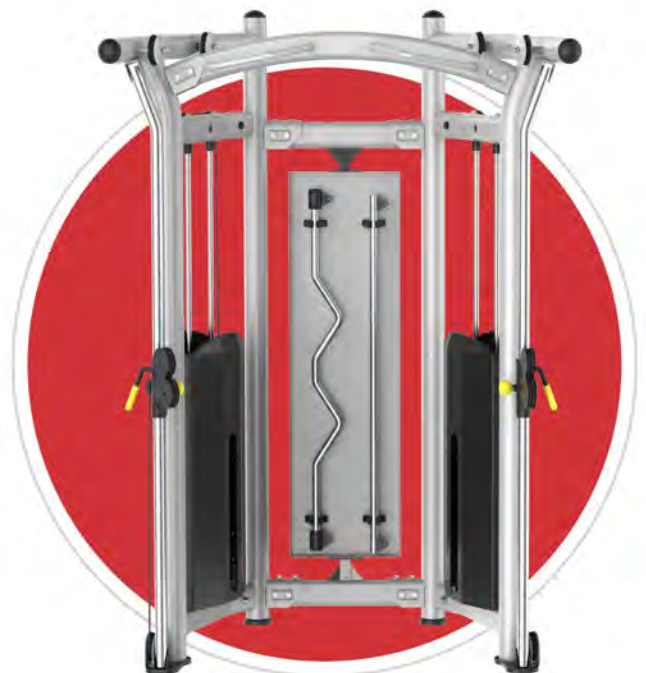

BEAST 21

OLYMPIC FLAT BENCH



BEAST 22

OLYMPIC INCLINE BENCH



BEAST 23

OLYMPIC DECLINE BENCH

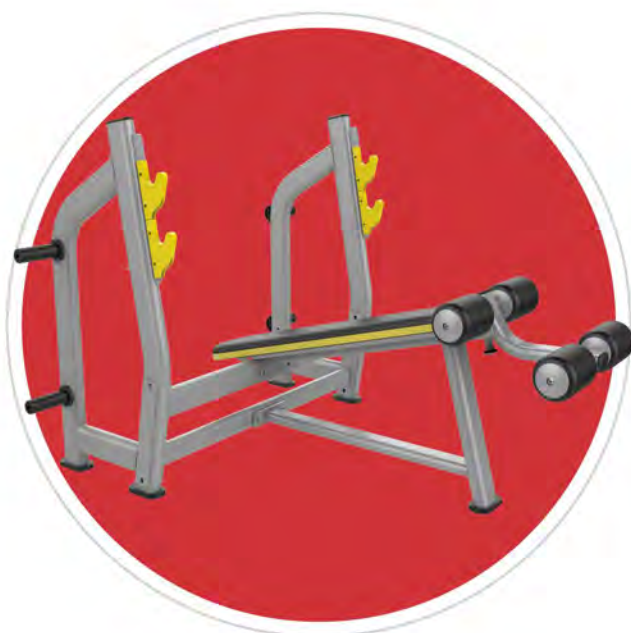

BEAST 24

HYPER EXTENSION



BEAST 25

VERTICAL KNEE
RAISE



BEAST 26

SEATED CALF



BEAST 27

AB BENCH



BEAST 28

STRETCH



BEAST 29

ADJUSTABLE AB
BENCH



BEAST 30

FLAT BENCH



BEAST 31

MULTI ADJUSTABLE BENCH



BEAST 32

UTILITY BENCH



BEAST 33

STANDING PREACHER CURL



BEAST 34

45° LEG PRESS



HS011

ABDUCTOR / ADDUCTOR

- LXWXH : 169X171X162 CM
- Weight stack : 165 LBS.



HS012

LEG EXTENSION / LEG CURL

- LXWXH : 166X104X162 CM
- Weight stack : 200 LBS.



HS013

MULTI PRESS

- LXWXH : 158X183X162 CM
- Weight stack : 220 LBS.



HS014

LAT PULL / SEATED ROW

- LXWXH : 203X113X221 CM.
- Weight stack : 220 LBS.



HS015

PEC FLY / REAR DELT

- LXWXH : 154X131X201 CM.
- Weight stack : 220 LBS.



HS016

BICEP / TRICEP

- LXWXH : 110X111X162 CM.
- Weight stack : 165 LBS.



HS017

LEG / CALF PRESS

- LXWXH : 190X106X185 CM
- Weight stack : 265 LBS.



HS034

CHIN DIP MACHINE

- LXWXH : 140X81X227 CM
- Weight stack : 200 LBS.



HS036

SEATED HORIZONTAL PULLEY

- LXWXH : 174X111X162 CM
- Weight stack : 220 LBS.



HS038

ABDOMINAL MACHINE

- LXWXH : 133X99X162 CM
- Weight stack : 200 LBS.



HS040

CHEST PRESS

- LXWXH : 150X125X162 CM
- Weight stack : 200 LBS.



HS042

SHOULDER PRESS

- LXWXH : 148X125X162 CM
- Weight stack : 220 LBS.



HS043

LAT PULLDOWN

- LXWXH : 132X123X185 CM
- Weight stack : 220 LBS.



HS047

PRONE LEG CURL

- LXWXH : 156X107X162 CM
- Weight stack : 200 LBS.



HS019

CABLE CROSSOVER

- LXWXH : 335X82X234 CM
- Weight stack : 200 LBS X 2.

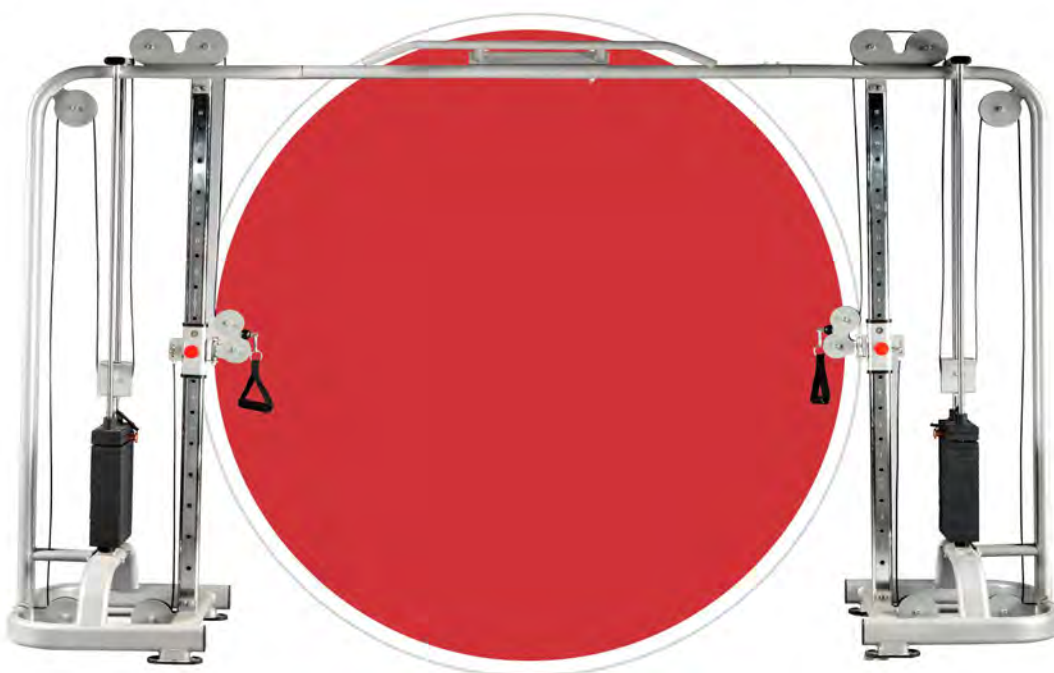

HS018

SMITH MACHINE

- LXWXH : 132X220X215 CM



HS020

DUMBBEL RACK

- LXWXH : 65X142X82 CM



HS021

45°HYPER EXTENSION BENCH

- LXWXH : 128X70X99 CM



HS022

FLAT BENCH

- LXWXH : 141X60X44 CM



HS023

ADJUSTABLE BENCH

- LXWXH : 124X65X52 CM



HS024

WEIGHT PLATE TREE

- LXWXH : 95X82X130 CM



HS028

SCOTT BENCH

- LXWXH : 90X83X90 CM



HS025

OLYMPIC FLAT BENCH

- LXWXH : 161X134X121 CM



HS026

OLYMPIC INCLINE BENCH

- LXWXH : 145X134X150 CM



HS027

OLYMPIC DECLINE BENCH

- LXWXH : 135X132X107 CM



HS029

CRUNCH BENCH

- LXWXH : 197X63X104 CM



HS030

ADJUSTABLE AB BOARD

- LXWXH : 174X70X130 CM



HS031

BARBELL RACK

- LXWXH : 59X125X88 CM



HS033

SEATED CALF RAISE

- LXWXH : 116X65X89 CM



HS051

AB BENCH



HS052

STRETCH MACHINE



HS032

VERTICAL KNEE RAISE

- LXWXH : 144X120X230 CM



HS053

LEG PRESS / HACK SQUAT

- LXWXH : 219X95X152 CM



E5001

PRONE LEG CURL

- LXWXH: 152X99X135 CM
- WEIGHT STACK : 210 LBS



E5002

LEG EXTENSION

- LXWXH: 130X99X135 CM
- WEIGHT STACK : 240 LBS



E5003

SEATED LEG PRESS

- LXWXH: 190X110X162 CM
- WEIGHT STACK : 255 LBS



E5005

LATRERAL RAISE

- LXWXH: 91X115X150 CM.
- WEIGHT STACK : 120 LBS



E5006

SHOULDER PRESS

- LXWXH: 185X122X132 CM
- WEIGHT STACK : 240 LBS



E5007

PEC FLY / REAR DELT

- LXWXH: 124X99X211 CM
- WEIGHT STACK : 240 LBS



E5008

CHEST PRESS

- LXWXH: 132X130X135 CM
- WEIGHT STACK : 240 LBS



E5009

DIP CHIN

- LXWXH: 155X137X236 CM
- WEIGHT STACK : 200 LBS



E5013

INCLINE CHEST PRESS

- LXWXH: 185X122X132 CM
- WEIGHT STACK : 240 LBS



E5023

SEATED LEG CURL

- LXWXH: 165X94X135 CM
- WEIGHT STACK : 240 LBS



E5030

BICEP CURL

- LXWXH: 119X89X135 CM
- WEIGHT STACK : 140 LBS



E5033

LONG PULL

- LXWXH: 282X109X236 CM
- WEIGHT STACK : 240 LBS



E5034

VERTICAL ROW

- LXWXH: 155X132X160 CM
- WEIGHT STACK : 210 LBS



E5035

LAT PULL DOWN

- LXWXH: 185X109X234 CM
- WEIGHT STACK : 240 LBS



E5084

MULTI PRESS

- LXWXH: 200X135X162 CM
- WEIGHT STACK : 240 LBS



E5088

ABDOMINAL / BACK EXTENSION

- LXWXH: 131X99X162 CM
- WEIGHT STACK : 240 LBS



E5086

LEG CURL /
LEG EXTENSION

- LXWXH: 140X120X162 CM
- WEIGHT STACK : 240 LBS



E5087

BICEP / TRICEP

- LXWXH: 140X120X162 CM
- WEIGHT STACK : 140 LBS



E5089

ABDUCTOR / ADDUCTOR

- LXWXH: 155X90X162 CM
- WEIGHT STACK : 210 LBS



E1082

AB COASTER

- LXWXH : 164x78x146 CM.



E3016

CABLE CROSSOVER

- LXWXH: 447X109X231 CM
- WEIGHT STACK : 220 LBS X 2

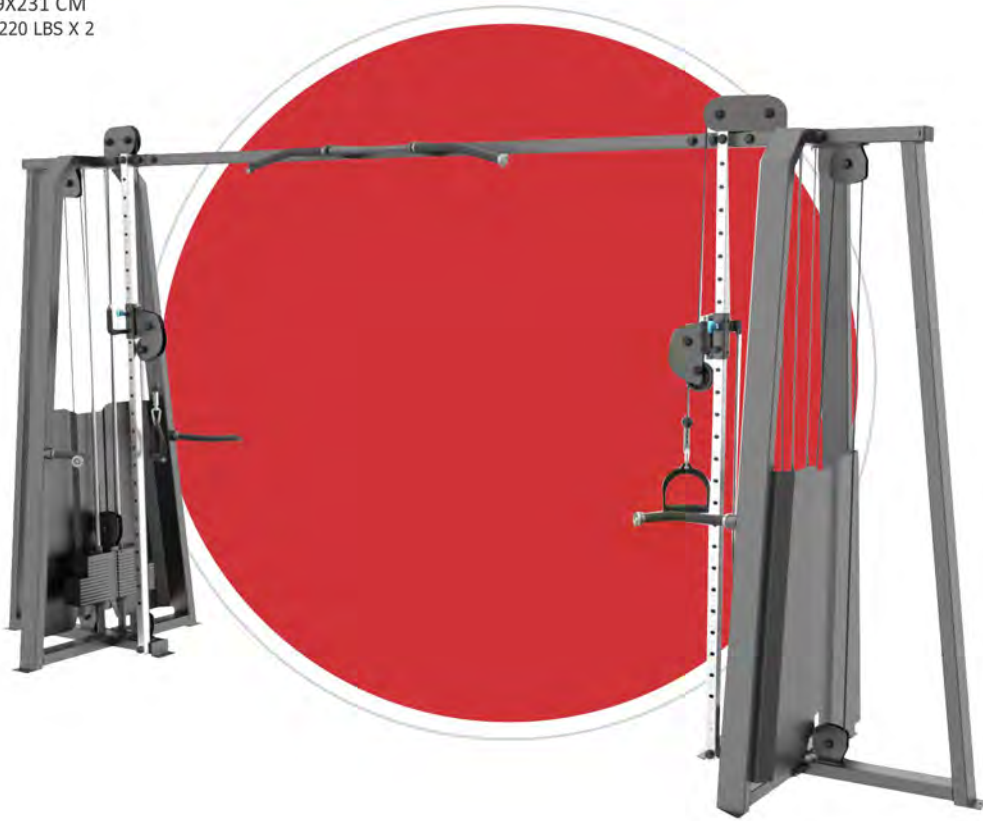

E1017

FUNCTIONAL TRAINER

- LXWXH: 105X176X225 CM
- WEIGHT STACK : 220 LBS X 2



E3036

FLAT BENCH

• LXWXH: 141X68X42 CM



E3037

ADJUSTABLE AB BENCH

• LXWXH: 164X68X99 CM



E3038

MULTI PURPOSE BENCH

• LXWXH: 106X68X90 CM



E3039

ADJUSTABLE BENCH

• LXWXH: 138X68X69 CM



E3041

OLYMPIC DECLINE BENCH

• LXWXH: 209X170X122 CM



E3042

OLYMPIC INCLINE BENCH

• LXWXH: 196X170X140 CM



E3043

OLYMPIC FLAT BENCH

• LXWXH: 174X170X122 CM



E3044

SEATED PREACHER CURL

• LXWXH: 113X84X88 CM



E3045

HYPER EXTENSION

• LXWXH: 121X89X67 CM



E3047

**DIP / VERTICAL
KNEE RAISE**

• LXWXH: 127X71X160 CM



E3048

POWER CAGE

• LXWXH: 157X124X234 CM



E3050

SQUAT RACK

• LXWXH: 173X170X178 CM



E3056

PLATE LOADED
LEG PRESS

• LXWXH: 221X63X135 CM



E3057

PLATE LOADED
HACK SQUAT

• LXWXH: 224X163X126 CM



E3061

T BAR

• LXWXH : 185x79x119 CM



E3062

SEATED CALF

• LXWXH: 150X71X99 CM



E3063

SMITH MACHINE

- LXWXH: 142X221X236 CM
- COUNTER BALANCED



E3065

SUPER SQUAT

- LXWXH: 185X79X119 CM



E3077

DUMBBELL RACK

- LXWXH: 72X248X81 CM



E3092

BOOTY MACHINE

- LXWXH: 201X163X147 CM.



E6233

WEIGHT PLATE BASE

- *LXWXH: 143X74X43 CM.



DFT601

PRONE LEG CURL

- LXWXH : 150x100x137 CM.
- Weight Stack:175 lbs.



DFT602

LEG EXTENSION

- LXWXH : 130x100x137 CM.
- Weight Stack:175 lbs.



DFT606

SHOULDER PRESS

- LXWXH : 185x125x137 CM.
- Weight Stack:220 lbs.



DFT607

PEC FLY / REAR DELT

- LXWXH : 125x100x210 CM.
- Weight Stack:220 lbs.



DFT608

CHEST PRESS

- LXWXH : 130x130x137 CM.
- Weight Stack:220 lbs.



DFT609

DIP CHIN MACHINE

- LXWXH : 155x137x236 CM.
- Weight Stack:175 lbs.



DFT616

CABLE CROSSOVER

- LXWXH : 335x110x235 CM.
- Weight Stack:220 LBS X 2.



DFT619

ABDOMINAL

- LXWXH : 120x100x137 CM.
- Weight Stack:175 lbs.



DFT623

SEATED LEG CURL

- LXWXH : 170x95x137 CM.
- Weight Stack:220 lbs.



DFT630

ARM CURL

- LXWXH : 114x94x137 CM.
- Weight Stack:175 lbs.



DFT633

LONG PULL

- LXWXH : 280x110x234 CM.
- Weight Stack:175 lbs.



DFT635

LAT PULL

- LXWXH : 185x110x234 CM.
- Weight Stack:220 lbs.



DFT690

BICEP / TRICEP

- LXWXH : 110X114X163 CM
- Weight Stack : 200 lbs



DFT691

LAT PULL / SEATED ROW

- LXWXH : 170X97X223 CM
- Weight Stack : 200 lbs



DFT692

LEG CURL / LEG EXTENSION

- LXWXH : 122X120X163 CM
- Weight Stack : 200 lbs



DFT693

ABDUCTOR / ADDUCTOR

- LXWXH : 157X88X163 CM
- Weight Stack : 200 lbs



DFT694

MULTI PRESS

- LXWXH : 157X88X163 CM
- Weight Stack : 200 lbs



DFT695

ABDOMINAL CRUNCH / BACK EXTENSION

- LXWXH : 108X104X163 CM
- Weight Stack : 200 lbs



DFT696

LEG / CLAF PRESS

- LXWXH : 182X107X163 CM
- Weight Stack : 200 lbs



DFT698

LEG PRESS / HACK SQUAT

• LXWXH : 208X92X149 CM



DFT636

FLAT BENCH

• LXWXH : 140x68x42 CM.



DFT637

MULTI AB BENCH

• LXWXH : 165x68x100 CM.



DFT638

UTILITY BENCH

• LXWXH: 106X68X90 CM



DFT639

ADJUSTABLE BENCH

- LXWXH : 138x68x69 CM.



DFT640

GLUTE HAM DEVELOPER (GHD)



DFT644

SEATED PREACHER CURL

- LXWXH : 132x84x97 CM.



DFT641

OLYMPIC DECLINE BENCH

- LXWXH : 210x170x125 CM.



DFT642

OLYMPIC INCLINE BENCH

- LXWXH : 196x170x140 CM.



DFT643

OLYMPIC FLAT BENCH

- LXWXH : 174x170x125 CM.



DFT645

HYPER EXTENSION BENCH

- LXWXH : 122x89x68 CM.



DFT647

VERTICAL KNEE RAISE / DIP STAND

- LXWXH : 127x70x96 CM.



DFT649

DUMBBELL RACK

- LXWXH : 72x25x80 CM.



DFT650

SQUAT RACK

- LXWXH : 173x170x180 CM.



DFT656

PLATE LOADING LEG PRESS

- LXWXH : 222x165x135 CM.



DFT657

PLATE LOADING HACK SQUAT

- LXWXH : 225x125x125 CM.



DFT662

STANDING CALF

- LXWXH : 150x70x100 CM.



DFT663

SMITH MACHINE

- Counter Balanced.



DFT671/679

FUNCTIONAL TRAINER

- LXWXH : 162x117x235 CM.
- Weight Stack:220 LBS x 2.



DFT683

SUPER SQUAT

- LXWXH: 185X79X119 CM



IFHC

HALF CAGE

- This base system provides the ultimate in safety and exercise variety.
- Self spotting triple chromed bar racking system for safer free weight solo workouts.
- Includes multiple plate holders for convenient racking.
- Adjustable safety spotters accommodates:
- LXWXH : 118X182X209 CM.



IFHCS

HALF CAGE SMITH ATTACHMENT

- Optional for IF-HC.
- LXWXH : 195X30X173 CM.



IFSS

SQUAT STAND

- Self spotting triple chromed bar racking system for safer solo workouts.
- Angled uprights for better squat and bench exercises.
- Multiple plate holders for convenient storage.
- Adjustable safety spotters
- LXWXH : 123X128X174 CM.



IF45

45°HYPEREXTENSION

- Adjustable thigh pads for proper positioning and support.
- 45 degree angle for optimal results.
- Dual transport wheels for easy movement.
- LXWXH : 121X74X77 CM.



IFAAB

ADJUSTABLE ABDOMINAL BENCH

- Over sized bench padding for maximum comfort.
- Dual transport wheels for easy movement.
- LXWXH : 168X57X115 CM.



IFAC

ABDOMINAL CRUNCH

- Fixed decline angle for basic abdominal workout.
- LXWXH : 110X48X58 CM.



IFPT

POWER TOWER

- Contoured arm rests for secure positioning.
- Angled back pad for added comfort.
- Multiple grip positions for easy chin ups, dips, push ups and leg raise.
- LXWXH : 132X61X210 CM.



IFSPC

SEATED PREACHER CURL

- Bar catch design for easy re-racking.
- Adjustable oversized arm pad.
- LXWXH : 102X71X82 CM.



IFFB

FLAT BENCH

- Wide base for added safety.
- LXWXH : 130X53X49 CM.
- Dual rear transport wheels for easy movement.



IFFID

MULTI PURPOSE BENCH

- Dual rear transport wheels for easy movement.
- Quick and easy seat and back pad adjustments.
- Fully adjustable decline to shoulder press.
- LXWXH : 158X65X52 CM.



IFOB

OLYMPIC BENCH

- Excellent adjustable uprights.
- Expandable with drop in attachment. Options - IF-LEGA & IF-ARMA.
- Fully adjustable decline to shoulder press.
- LXWXH : 144X126X147 CM.



IFOFB

FLAT BENCH

- LXWXH : 152.5X131X126.5 CM.



IFOIB

INCLINE BENCH

- LXWXH : 156X131X119.2 CM.

IFODB

DECLINE BENCH

- LXWXH : 190X131X115.6 CM



IFDB4

4FT HORIZONTAL DUMBBELL RACK

- For easy racking and unranking.
- Ideal for larger dumbbells sets.
- Can be converted into a 3 tier rack by adding IF-DB4A
- LXWXH : 137X47X87 CM.

IFDB4A

4FT DUMBBELL RACK 3RD TIER OPTION

- Optional for IF-DB4.
- LXWXH : 124X24X74 CM.

IFPTO

OLYMPIC PLATE TREE

- Unique design that optimises storage space.
- LXWXH : 84X83X111 CM.



SL SERIES UNIQUE FEATURES

Easy to use, neat appearance, the SL line is a high quality commercial plate loaded series. The user-friendly design makes working out more simple, efficient, comfortable and satisfying.

Tubing: thickness range from 2.5 mm to 3mm, 50mmx100mm tubing, electro-welded to maximum integrity.

Color: black and red (Other colors are optional based on customer requirements)

Finish: Electrostatic powder-coated and heat cured after adhesiveness enhancement pre-treatment for superior durability



Compact - space efficient design requires minimal floor space.

Pad total thickness is 70mm.

Easy-to-use, flexible adjustments allow for optimal exercise positions.



SL7001

CHEST PRESS

- LXWXH : 193.7X137X171 CM.
- MAX WEIGHT CAPACITY:300Kg/660Lbs



SL7002

PULL DOWN

- LXWXH : 148.2X148.9X196.7 CM.
- MAX WEIGHT CAPACITY:300Kg/660Lbs



SL7003

SHOULDER PRESS

- LXWXH : 155.8X181.8X148.7 CM.
- MAX WEIGHT CAPACITY:300Kg/660Lbs



SL7004

LOW ROW

- LXWXH : 176.1X145.7X165.2 CM.
- MAX WEIGHT CAPACITY:300Kg/660Lbs.



SL7005

INCLINE CHEST PRESS

- LXWXH : 190X152.3X177.9 CM.
- MAX WEIGHT CAPACITY:300Kg/660Lbs.



SL7006

LEG PRESS

- LXWXH : 222.6X142.1X141.9 CM.
- MAX WEIGHT CAPACITY:400Kg/880Lbs.



SL7007

ROW

- LXWXH : 181.5X150X133.4 CM.
- MAX WEIGHT CAPACITY:300Kg/660Lbs.



SL7008

REAR KICK

- LXWXH : 168X122.9X163.6 CM.
- MAX WEIGHT CAPACITY:150Kg/330Lbs.



SL7009

OLYMPIC POWER RACK

- LXWXH : 203.1X144.9X227.8 CM.



SL7010

PLATE RACK

- LXWXH : 89.1X62.8X122.8 CM.



SL7011

FID BENCH

- LXWXH : 135X67X135 CM.



SL7012

FID BENCH

- LXWXH: 155X67X135 CM.



SL7013

GLUTE HAM BENCH

- LXWXH: 156.2X91.4X147.7 CM.



SL7014

HALF RACK

- LXWXH : 139X174.7X244.2 CM.



SL7016

DUMBBELL RACK

- LXWXH : 226x76x74CM



SL7017

SEATED CALF RAISE

- LXWXH: 147.5X76.5X84.5 CM.
- MAX WEIGHT CAPACITY: 150 KG/330 LBS



SL7018

ARM CURL

- LXWXH : 114x86x102CM



SL7019

INCLINE ROW

- LXWXH : 196 X 102 X 125.3 (CM)
- Maximum Weight Capacity : 150kg / 330 LBS



SL7020

45° LEG PRESS

- LXWXH: 249.9X187.9X154.4 CM.
- MAX WEIGHT CAPACITY:450Kg/990Lbs.



SL7021

HACK SQUAT

- LXWXH:220.5x188x128.5 CM
- MAX WEIGHT CAPACITY:400Kg/880Lbs



SL7022

UTILITY BENCH

- LXWXH : 119.1X63X82.2 CM.



SL7023

BICEP CURL

- LXWXH : 140.3X104.5X120 CM.
- MAX WEIGHT CAPACITY:300Kg/660Lbs.



SL7024

TRICEP DIP

- LXWXH: 173.3X158X120.2 CM.
- MAX WEIGHT CAPACITY: 300 KG/660 LBS



SL7025

LEG EXTENSION

- LXWXH: 127X169X100.5 CM.
- MAX WEIGHT CAPACITY: 300 KG/660 LBS



SL7026

STANDING LEG CURL

- LXWXH: 140.3X104.5X120 CM
- MAX WEIGHT CAPACITY: 120 KG/264 LBS



SL7027

BARBELL RACK

- LXWXH : 95X91X161.2 CM



SL7028

FLAT BENCH PRESS

• LXWXH: 191X173.8X131.5 CM



SL7029

INCLINE BENCH PRESS

• LXWXH: 205.9X173.8X149.6 CM



SL7030

DECLINE BENCH PRESS

• LXWXH: 218.8X173.8X131.5 CM



SL7031

SHOULDER BENCH PRESS

• LXWXH : 171.9X126.1X192 CM



SL7032

STANDING CALF RAISE

- LXWXH: 161.5X137.5X173 CM
- MAX WEIGHT CAPACITY: 300 KG/660 LBS



SL7034

SQUAT

- LXWXH: 226X126X180 CM
- MAX WEIGHT CAPACITY: 400 KG/880 LBS



SL7035

FLAT BENCH

- LXWXH: 128.1X63X52.5 CM.
- MAX WEIGHT CAPACITY: 400 KG/880 LBS



SL7036

ABDOMINAL

- LXWXH: 162.3X126.7X164.2 CM.
- MAX WEIGHT CAPACITY: 300 KG/660 LBS



SL7041

SUPER OLYMPIC BENCH

- LXWXH : 241X174.3X162.2 CM



SL7042

MAGIC RACK / SMITH MACHINE

- LXWXH : 231.5X224.1X239.1 CM



SL7043

MULTI AB BENCH

• LXWXH : 172.2X63X91.2 CM



SL7044

STRETCH MACHINE

• LXWXH : 156.7X63X126.3 CM



SL7045

VERTICAL KNEE RAISE / DIP STAND

• LXWXH : 118.9X76.5X135.7 CM



SL7047

HYPER EXTENSION BENCH

• LXWXH : 134X94.7X76.5 CM



JPL302

SHOULDER PRESS

- LXWXH : 129X128X146 CM
- MAX WEIGHT CAPACITY : 250Kg/550Lbs



JPL303

CHEST PRESS

- LXWXH : 122X141.6X164.5 CM
- MAX WEIGHT CAPACITY : 250Kg/550Lbs



JPL304

PULL DOWN

- LXWXH : 112X138.5X124.7 CM
- MAX WEIGHT CAPACITY : 250Kg/550Lbs



JPL305

ROW

- LXWXH : 118X138.8X124.7 CM
- MAX WEIGHT CAPACITY : 250Kg/550Lbs



JPL306

LOW ROW

- LXWXH : 120X122.3X163.3 CM
- MAX WEIGHT CAPACITY : 250Kg/550Lbs



JPL307

LEG PRESS

- LXWXH : 145X210X135.5 CM
- MAX WEIGHT CAPACITY : 300Kg/660Lbs



JPL308

INCLINE CHEST PRESS

- LXWXH : 153.5X103X164 CM
- MAX WEIGHT CAPACITY : 250Kg/550Lbs



JPL309

HACK SQUAT

- LXWXH : 90X170X112 CM
- MAX WEIGHT CAPACITY : 250Kg/550Lbs



JPL310

REAR KICK

- LXWXH : 111.5X143X164 CM
- MAX WEIGHT CAPACITY : 250Kg/550Lbs



JPL312

TRICEP DIP

- LXWXH : 147X154X86 CM
- MAX WEIGHT CAPACITY : 250Kg/550Lbs



JPL313

BICEP CURL

- LXWXH : 106X138.5X100.5 CM
- MAX WEIGHT CAPACITY : 250Kg/550Lbs



JPL314

STANDING LEG CURL

- LXWXH : 144X116.5X142 CM
- MAX WEIGHT CAPACITY : 250Kg/550Lbs



JPL315

LEG EXTENSION

- LXWXH : 124X126X116.5 CM
- MAX WEIGHT CAPACITY : 250Kg/550Lbs



JPL316

LINEAR LEG PRESS

- LXWXH : 269.5X156.8X150 CM
- MAX WEIGHT CAPACITY : 400Kg/880Lbs



JPL317

LINEAR LEG PRESS

- LXWXH : 269.5X156.8X150 CM
- MAX WEIGHT CAPACITY : 400Kg/880Lbs



X50

PORTABLE SQUAT STAND

- Can be used as both for squats & bench press exercises.



X100

MULTI PURPOSE BENCH

- Flat, incline & decline position
- With preacher curl attachment
- With leg extension & prone leg curl



X200

PLATE LOADED STRENGTH TRAINER

- DIMENSIONS : 175X170X220 CMS
- MAXIMUM WEIGHT LOADING CAPACITY : 120 KGS



X400

WALL MOUNTED FOLDABLE SQUAT RACK

- DIMENSIONS : 115X138X230 CMS
- MAXIMUM WEIGHT LOADING CAPACITY : 200 KGS

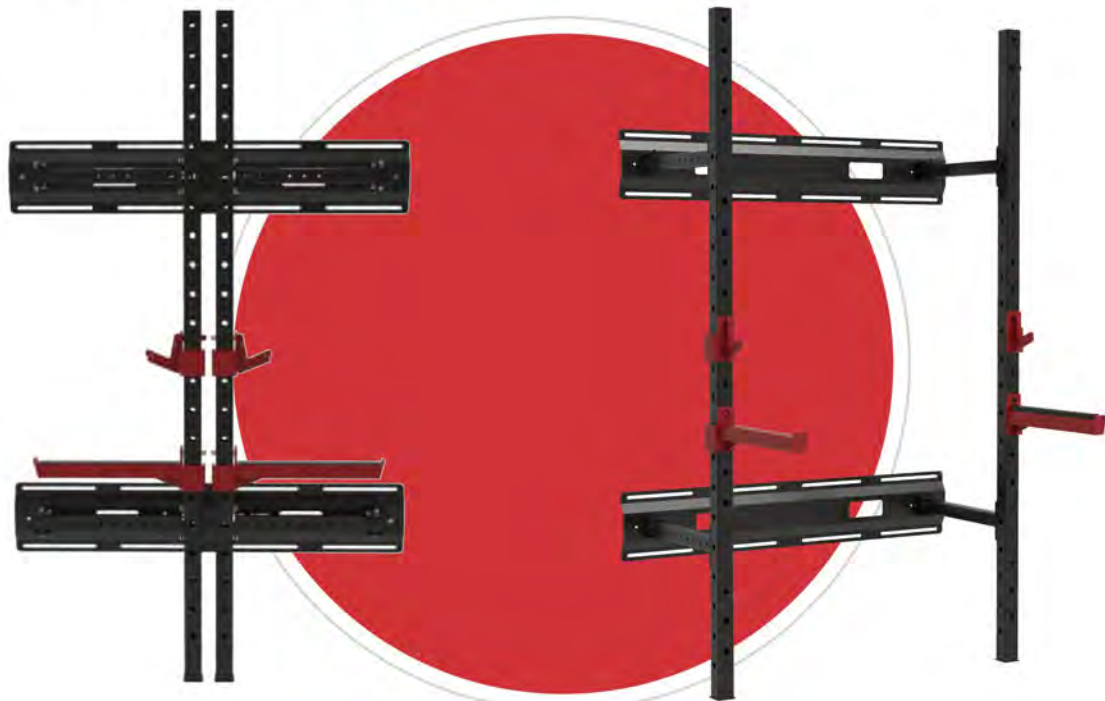

X500

HALF RACK

- DIMENSIONS : 126X180X232 CMS
- MAXIMUM WEIGHT LOADING CAPACITY : 200 KGS



X600

FUNCTIONAL RACK WITH LONG PULL

- DIMENSIONS : 154X170X232 CMS
- MAXIMUM WEIGHT LOADING CAPACITY : 120 KGS



X800

PLATE LOADED FTSM

- PLATE LOADED FUNCTIONAL TRAINER CUM SMITH MACHINE
- DIMENSIONS : 205X222X232 CMS
- MAXIMUM WEIGHT LOADING CAPACITY : 200 KGS



X900

FTSM

- FUNCTIONAL TRAINER CUM SMITH MACHINE
- DIMENSIONS : 205X147X232 CMS
- WEIGHT STACK OF 80 KG X 2
- MAXIMUM WEIGHT LOADING CAPACITY : 200 KGS



SAVAGE

- FUNCTIONAL TRAINER CUM SMITH MACHINE CUM MULTI GYM
- DIMENSIONS : 180X219X227 CMS
- WEIGHT STACK OF 100 KG X 2
- MAXIMUM WEIGHT LOADING CAPACITY : 200 KGS



ROBO ARM 22

- STURDY DESIGN
- Weight stack : 200lbs x 2
- LXWXH : 246X359X249 cm



FTSM

FUNCTIONAL TRAINER CUM SMITH MACHINE

- STURDY DESIGN
- Heavy duty oval tube structure of size 50mm x 100mm.
- Tube thickness 2.5mm.
- Weight Stack of 80 Kg X 2



KH309

STRETCH RACK

- STURDY DESIGN
- Ideal for stretching exercise
- LXWXH : 155X107X228 cms



KH270

SQUAT PLATFORM

- Sturdy Design.



KH271

SISSY SQUAT

- Sturdy Design.



KH275

WRIST CURL

- Sturdy Design.
- Wight Stack : 175 lbs



KH304

BARBELL RACK

- Sturdy Design
- LXWXH : 86X63X33 cms



KH290

BARBELL RACK

- Sturdy Design.



KH295

MULTI PLATE RACK

- Sturdy Design.



KH305

DUMBBELL RACK

- Sturdy Design.
- LXWXH : 243X73X82.5 CM.



KH306

PLATE TREE

- Sturdy Design.
- LXWXH : 67X67X116 CM.



KH307

BARBELL RACK

- Sturdy Design.
- LXWXH : 125X84X149 CM.



718LP ENDURANCE

HEAVY DUTY COMMERCIAL MULTI GYM

- STATE OF ART design with heavy duty steel structure
- 4 station gym with
3 STEEL weight stacks of 90 Kgs each
- Multiple Exercise Function -
Leg press, Multi press, Lat pull, Pec fly / Rear delt,
Dip / Chin with Vertical knee raise stand.
- Comfortable seat pads.
- Durable power coated finish.
- Ergonomic Design / Scientific Bio-mechanics.
- Arc cover for protection.
- LXWXH : 310X280X210 CM.

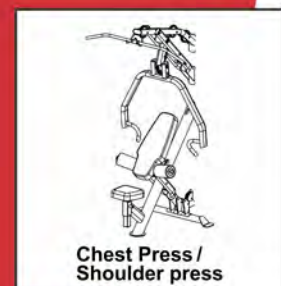
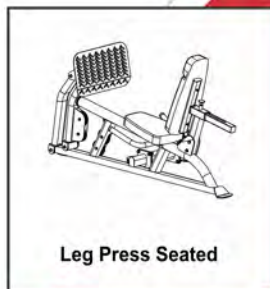
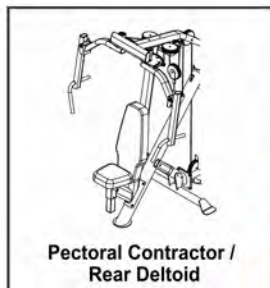

618LP ENDURANCE

HEAVY DUTY COMMERCIAL MULTI GYM

- State-of-the-art design with heavy duty steel structure
- 4 station gym with 3 steel weight stacks of 90 Kgs each
- Multiple Exercise Function – Leg press, Shoulder press, Chest press, Lat pull, Seated row and all high / low pulley exercises
- Comfortable seat pads
- All weight stacks attached at right angle for maximum space saving when placed in a corner
- Durable powder coated finish
- Arc cover for protection
- LXWXH : 269X239X216 CM



318LP

MULTI GYM

- Innovative design and ideal for corporate & society use
- Multi station gym with 1 steel weight stacks of 90 Kgs.
- Multiple Exercise Function – Seated bench press, Row, Pull down, Chest clamp, Tricep push down, Standing abdominal curl, Leg extension, Standing leg curl, Standing bicep curl, Golf, Arm extension, Front raise, Shrugs & Leg press.
- Durable powder coated finish
- Comfortable seat pads
- Arc cover for protection



518BI KARIZMA

COMMERCIAL MULTI GYM

- 4 station gym with 2 weight stacks of 72 Kgs each.
- Exercise Function - Leg press, Leg extension, Chest press, Pec fly, Lat pull, Rowing, Knee raise, Push up stand etc.
- Durable power coated finish.
- Ergonomic Design / Scientific Biomechanics.
- Arc cover for protection.



418CA STAR

COMMERCIAL MULTI GYM

- Innovative design & ideal for corporate or society use.
- 6 station gym with 2 STEEL weight stacks of 70 Kgs each.
- Multiple Exercise Function - Leg extension, Leg press, Hi-Lo pulley, Tricep extension, Lat pull, Bicep curl, Pec Dec, Multi press, Abdominal crunch, Bicep curl, Bench press, Vertical knee raise, Chin up & Dips stand etc.
- Durable powder coated finish.
- Comfortable seat pads.
- Arc cover for protection.



318MG

MULTI GYM

- Innovative design and ideal for corporate & society use
- Multi station gym with 1 steel weight stacks of 90 Kgs.
- Multiple Exercise Function – Seated bench press, Row, Pull down, Chest clamp, Tricep push down, Standing abdominal curl, Leg extension, Standing leg curl, Standing bicep curl, Golf, Arm extension, Front raise & Shrugs.
- Durable powder coated finish
- Comfortable seat pads
- Arc cover for protection



518LC CHAMPION

LIGHT COMMERCIAL MULTI GYM

- 4 station gym with 4 weight stacks of 68 Kgs each.
- Exercise Function - Leg press, Chest press, Leg extension, Pec fly, Lat pull, Bicep curl, Rowing etc.
- Durable power coated finish.
- Ergonomic Design / Scientific Biomechanics.

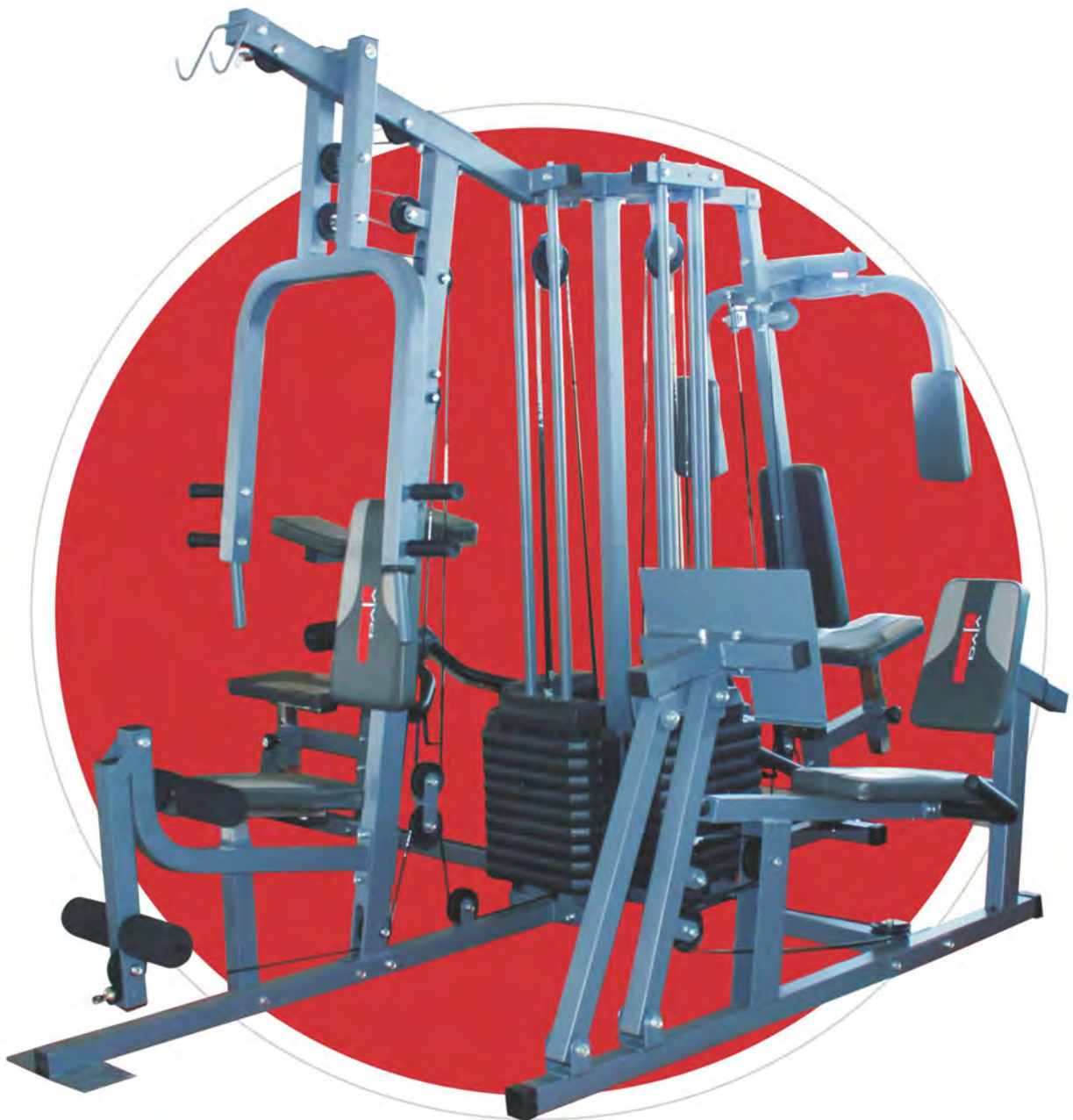

418BA STELLA

LIGHT COMMERCIAL MULTI GYM

- Innovative design & ideal for corporate or society use.
- 5 station gym with 2 weight stacks of 90 Kgs & 65 Kgs each.
- Multiple Exercise Function - Leg extension, Leg press, Hi-Lo pulley, Chin up, Lat pull, Bicep curl, Pec Dec, Multi press, Tricep extension, Abdominal crunch, Bicep curl, Bench press, Vertical knee raise etc.
- Durable power coated finish.
- Comfortable seat pads.
- Arc cover for protection.



IMPULSE ZONE

Customized Group Functional Training



TOP VIEW



X-SHAPE

PRODUCT DIMENSION
7489x3139x2446 (mm)
294.8x123.6x96.3 (in)



TOP VIEW

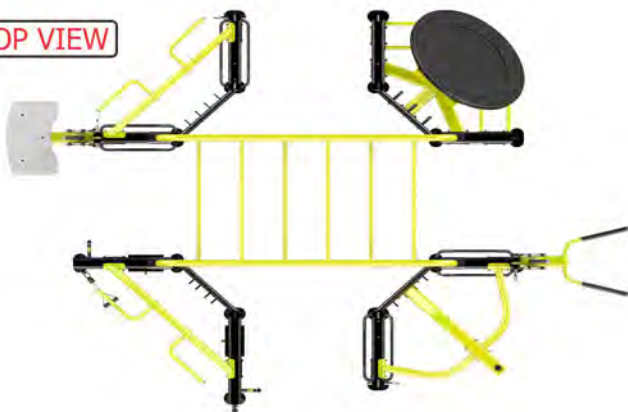

O-SHAPE

PRODUCT DIMENSION
3590x3473x2447 (mm)
141.3x136.7x96.3 (in)

IMPULSE ZONE

Customized Group Functional Training



TOP VIEW

I-SHAPE

PRODUCT DIMENSION
4794x1654x2446 (mm)
188.7x65.1x96.3 (in)

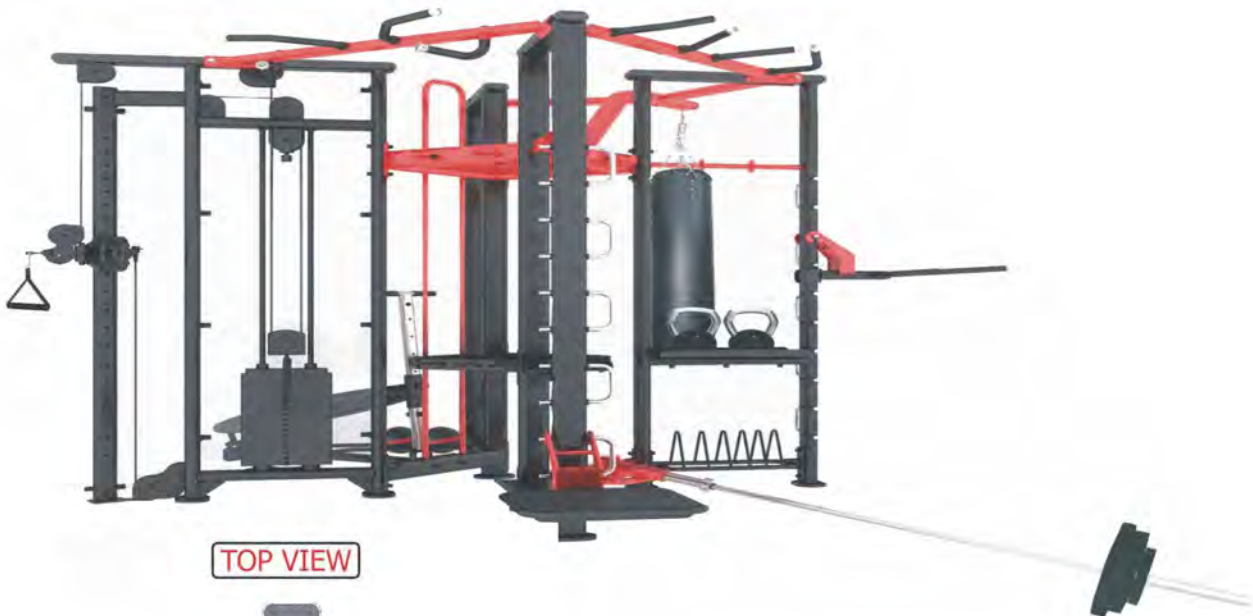
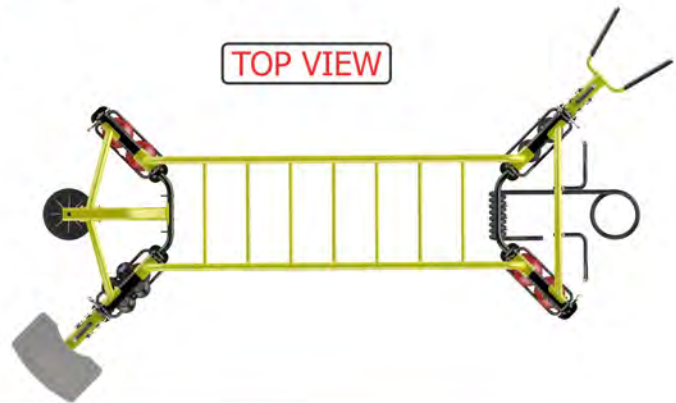

TOP VIEW

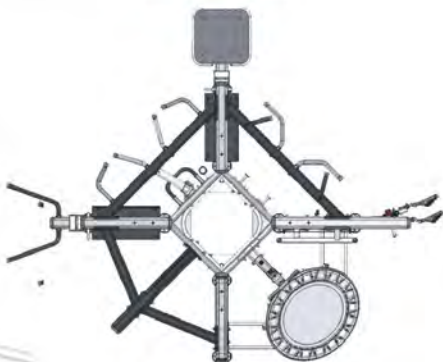

D-SHAPE

PRODUCT DIMENSION
3235x2855x2400 (mm)
127.3x112.4x94.4 (in)

ENERGY 360

WITH ACCESSORIES



 <p>8 PCS TRX</p>	 <p>9 METERS</p>	 <p>MEDICINE BALL 5 SETS</p>	 <p>2 PAIRS</p>	 <p>5 SETS</p>	 <p>5 SETS</p>	 <p>5 SETS</p>
---	--	--	---	--	--	--

SMART 360



KH308

SUSPENSION TRAINING RACK

- Sturdy Design.
- LXWXH : 312X206X251 CM.

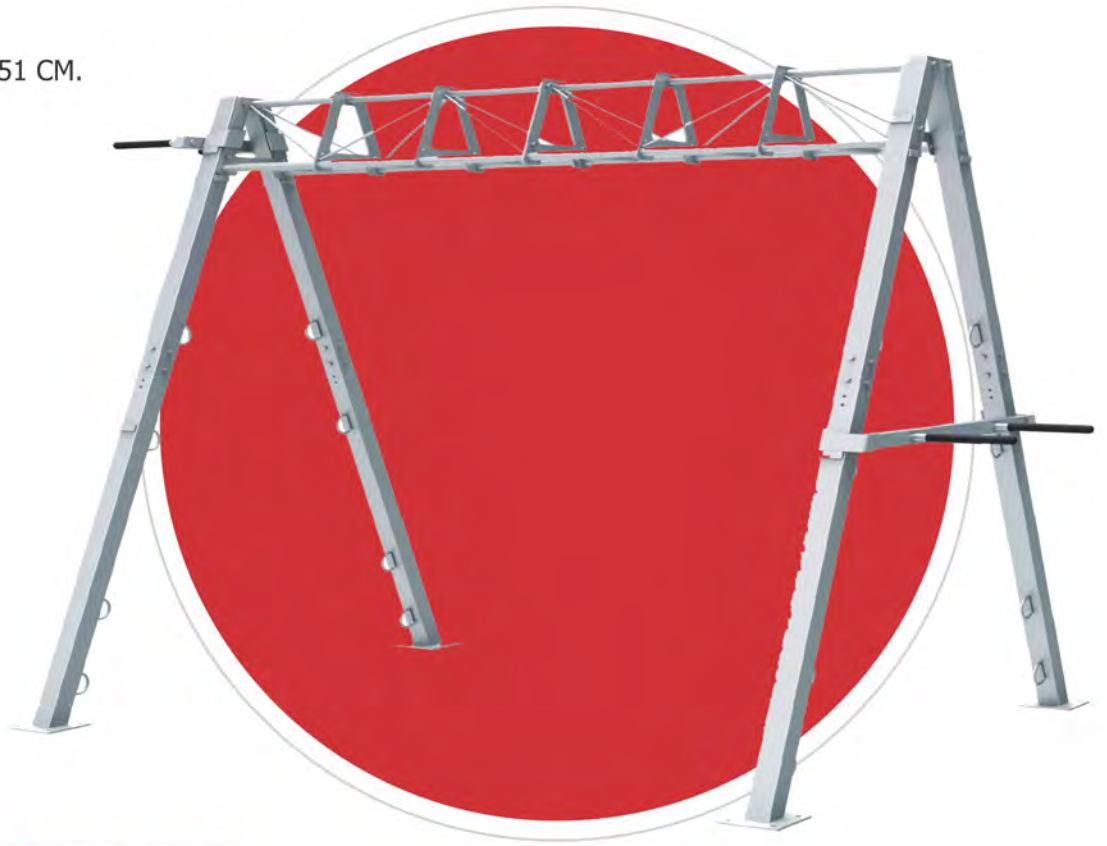

WEIGHT LIFTING PLATFORM

- Heavy duty steel platform.
- The assembly size is 256CM X 194CM X 5CM thickness.
- The bamboo board size is 184CM X 122CM X 3CM.



RUBBER COATED FIXED BARBELLS WITH STRAIGHT AND CURL HANDLE BAR

- Made from high grade virgin rubber for long life.
- Dia 30mm and length 100cm.
- Tear proof, soundless & bouncy effect.



AVAILABLE SIZES
KGS
10
15
20
25
30
35
40

VIVA FITNESS TPR SOLID DUMBBELL

- Made from high grade thermoplastic rubber for long life.
- Tear proof, soundless & bouncy effect.



AVAILABLE SIZES
KGS
2.5
5
7.5
10
12.5
15
17.5
20
22.5
25
30
35
40
45
50

RUBBER COATED SOLID DUMBBELL

- Tear proof, soundless & bouncy effect.



AVAILABLE SIZES
KGS
2.5
5
7.5
10
12.5
15
17.5
20
22.5
25
30
35
40
45
50

UNBRANDED ROUND DUMBBELLS



AVAILABLE SIZES
KGS
2.5
5
7.5
10
12.5
15
17.5
20
25

RUBBER COATED HEXAGON DUMBBELL



AVAILABLE SIZES
KGS
2.5
5
7.5
10
12.5
15
17.5
20
25

COMPETITION

BUMPER PLATES

- Coloured competition bumper plates.
- In 5 kgs middle steel plate is of 130 mm & in rest of sizes it is 190 mm.



AVAILABLE SIZES
KGS
5
10
15
20
25

COLOURED

BUMPER PLATES

- Made from high quality rubber.



AVAILABLE SIZES
KGS
5
10
15
20
25

BLACK

BUMPER PLATES

- Made from high quality rubber.



AVAILABLE SIZES
KGS
5
10
15
20
25

VIVA FITNESS TPR

OLYMPIC HOLE PLATES

- Made from high grade thermoplastic rubber for long life.
- Tear proof, soundless & bouncy effect.



AVAILABLE SIZES
KGS
1.25
2.5
5
7.5
10
15
20
25

VIVA FORCE

OLYMPIC HOLE PLATES

- Made from high grade virgin rubber for long life.
- Tear proof, soundless & bouncy effect



AVAILABLE SIZES
KGS
1.25
2.5
5
7.5
10
15
20
25

COLOURED

RUBBER PLATES

- Available in both olympic & 29 mm hole
- Tear proof, soundless & bouncy effect.



AVAILABLE SIZES
KGS
1.25
2.5
5
7.5
10
15
20
25

COMPETITION

KETTLE BELL



AVAILABLE SIZES
KGS
8
12
16
20
24
28
32

NEOPRENE

KETTLE BELL



AVAILABLE SIZES
KGS
2
4
8
12
16
20
24
28
32

IR101

COMPETITION OLYMPIC BAR

- Hard chrome tempered alloy steel
- Max loading : 2000 lbs
- Length : 2.2 mtrs
- Handle shaft length : 1.31 meter
- Handle shaft Dia : 29 mm



IR94088

STRONGMAN THICK BARBELL

- Unique 50 mm grip bar
- Hard chrome tempered alloy steel
- Max loading : 1600 lbs
- Length : 2.2 mtrs*Weight : 44 lbs



IR94039

HEAVY DUTY OLYMPIC BAR

- Heat treatment grip bar
- Max loading : 1000 lbs
- Length : 2.2 mtrs



POUND PAD



IR94051

60" OLYMPIC BAR



IR94052

72" OLYMPIC BAR



IR102

MULTI GRIP BAR

Size : 2.2 meter



IR94047

47" EZ CURL BAR



IR94045

OB20" OLYMPIC BAR



IR94083

56" OLYMPIC BAR



IR94046

OLYMPIC TRICEP BAR



IR94025

14" REGULAR RUBBER HANDLE HOLLOW BAR

- Matches our small hole rubber plates



IR94065

OLYMPIC BAR COLLAR (STEEL)



IR95069

NYLON LAT ROPE



IR95017

38" SOLID LAT BAR



IR95021



IR95023



IR94025



IR95019



IR95029



IR94064

OLYMPIC BAR COLLAR (PLASTIC)



IR94061

COLLAR



IR95015

48" SOLID LAT BAR



IR95020

20" SOLID LAT BAR



IR95022



IR95024



IR95026



IR94084



IR95028



POWER SLED WITH TYRE

- Minimum storage space required.
- Multi-level grip positions.
- Full range of functional movements.
- Maximum load capacity : 400 kgs.



WEIGHT SLED HYPER

- Heavy metal Construction with Shoulder Harness
- Good for all Push Pull
- Drag Sports & Speed Training
- All Fold-able for Easy Transportation
- Dual side operational



WEIGHT SLED TRIO

- Heavy metal Construction
- Must for all Push Pull Drag Sports & Speed Training
- Good for all Push Pull Drag Sports & Speed Training
- All Fold-able for Easy Transportation
- Dual side operational



WEIGHT SLED MINI

- Metal Construction with Shoulder Hardness
- Must for all Push Pull Drag Sports & Speed Training
- Good for all Push Pull Drag Sports & Speed Training
- Drag Sports & Speed Training
- All Fold-able for Easy Transportation
- Dual side operational



FLIP TYRE

- Large Dia tyre made from pre-used rubber
- Develops Power and Strength
- Good for Functional Training
- FTU100 (100 kgs.)
- FTU70 (70 kgs)
- FTU50 (50 kgs)





Dimensions: L 229cm x W 80cm x H 218cm (Carriage W 62cm x H 62cm)

Weight: 165kgs

Features included: Reformer, Platform Extender, Stainless Steel Full Trapeze Tower, Pair of Fluffy Hand Straps, Horizontal Steel Cross Bar, Rehab Legs, Built-in Standing Platform, Sitting Box, Jumpboard, Pulley Risers, 8 x Additional Deluxe Springs

Specifications

- Adjustable Pulley Risers with swivel pulleys provide ergonomic angle of ropes
- Durable braided ropes with cleated rope-clamping system for easy access and adjustability
- Adjustable high-density padded headrest (3 positions) for neck support
- Removable high-density padded shoulder rests
- Padded double-loop straps provide 3 different grip configurations (hand/foot/sandal) for a wider range of Pilates exercises
- Wide high-density EVA foam Padded Carriage is soft but supportive
- Adjustable feet-anchor strap at base for stability and posture while performing additional exercises
- Beautiful hand-sanded European Beech wood Frame
- Commercial quality stainless steel Full Trapeze Tower with 16 carbine attachment point
- High-density EVA foam Padded Platform Extender is soft but supportive, converting the reformer carriage into a much larger stable platform for a range of additional trapeze exercises
- Padded stainless steel Push-Through Bar with heavy-duty nylon safety strap
- Beech Roll-Down Bar
- Beech Trapeze bar with heavy duty nylon foot strap
- 8 additional stainless steel deluxe springs
- 2 double-Loop Straps provide 3 different grip configurations (hand/foot/sandal) for a wider range of Pilates exercises
- One pair of deluxe fluffy hand straps
- One adjustable horizontal stainless steel crossbar with 2 carbine attachment points
- High-Set "Rehab" legs

Features

- The new premium 8-wheel "dual-angle treaded roller" system with high-quality bearings and stainless steel rails for whisper quiet operation and the smoothest carriage glide
- Five deluxe smooth springs, 2x green (light resistance) 2x yellow (medium resistance) 1 x red (hard resistance)
- Detachable padded jump board (included)
- Large Sitting box (included)
- Built-in standing platform (included)
- Quick-Release Adjustable foot bar with non-slip padding



Dimensions: L-226cm x W-61cm x H-198cm (Carriage Height 31cm)

Weight: 120kgs

Features included: Reformer, Platform Extender, Stainless Steel Half Trapeze Tower, Built-in Standing Platform, Sitting Box, Jump-board, 6 x additional deluxe springs

Specifications:

- Adjustable Pulley Risers with swivel pulleys provide ergonomic angle of ropes
- Durable braided ropes with cleated rope-clamping system for easy access and adjustability
- Adjustable high-density padded head rest (3 positions) for neck support
- Removable high-density padded shoulder rests
- Padded double-loop straps provide 3 different grip configurations (hand/foot/sandal) for a wider range of Pilates exercises
- Wide high-density EVA foam Padded Carriage is soft but supportive
- Adjustable feet-anchor strap at base for stability and posture while performing additional exercises
- Beautiful hand-sanded European Beech wood Frame
- Stainless Steel Half Trapeze Tower with 11 carbine attachment points
- High-density EVA foam Padded Platform Extender is soft but supportive, converting the reformer carriage into a much larger stable platform for a range of additional trapeze exercises
- Padded stainless steel Push-Through Bar with heavy-duty nylon safety strap
- Beech Roll-Down Bar
- 6 additional soft-sheathed stainless steel deluxe springs (2 x Red Hard, 2 x Yellow Medium, and 2 x Long)
- 2 additional double-Loop Straps provide 3 different grip configurations (hand/foot/sandal) for a wider range of Pilates exercises

Features:

- The new premium 8-wheel "dual-angle treaded roller" system with high quality bearings and stainless steel rails for whisper quiet operation and the smoothest carriage glide.
- Five deluxe smooth springs, 2x green (light resistance) 2x yellow (medium resistance) 1 x red (hard resistance)
- Includes a Detachable padded jumpboard, Large Sitting Box, Built-in standing platform
- Quick-Release Adjustable foot bar with non-slip padding

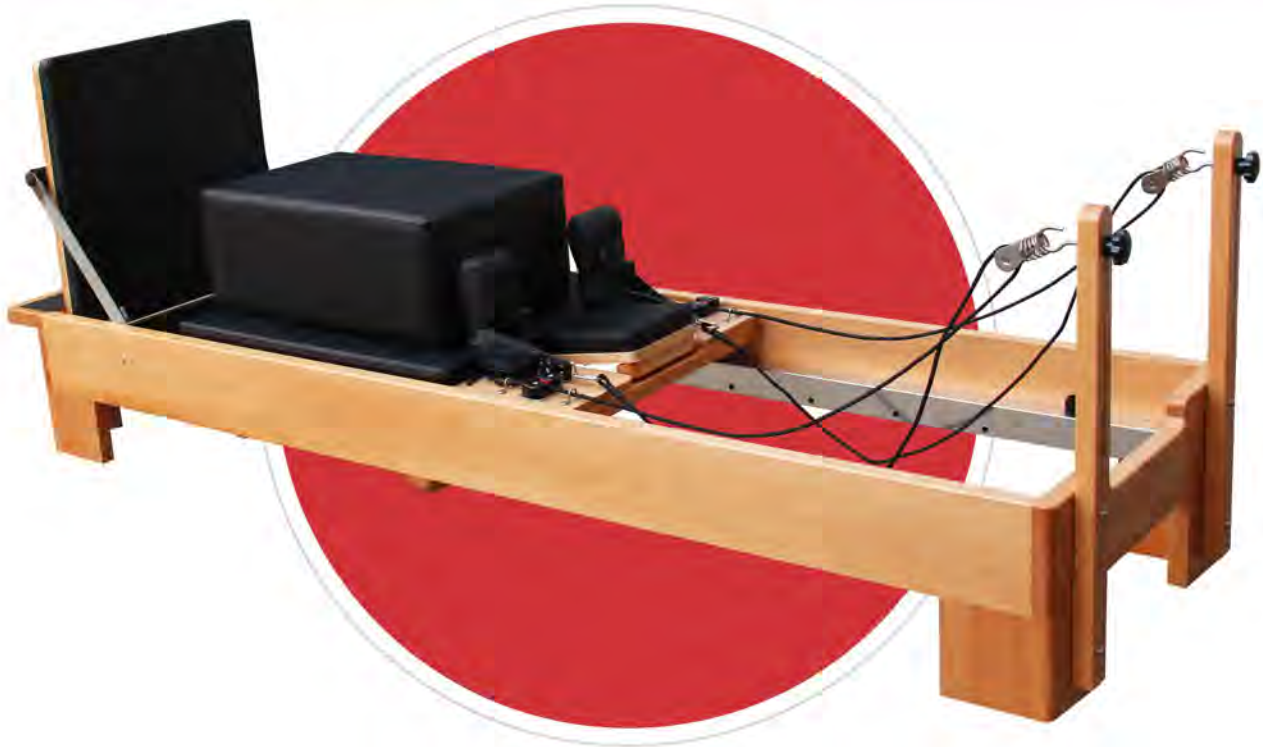

Dimensions: L 238cm x W 69cm x H 32cm

Weight: 80 kg

Features included: Sitting Box, Standing Platform, Jumpboard, Commercial Grade Springs, 8 wheel dual angle treaded roller system, Quick Release Adjustable Foot Bar, Adjustable Foot strap, Pulley Rises, Sturdy Beechwood Frame, Optional Half Trapeze attachment

Description

The Studio Reformer offers extraordinary flexibility & versatility suitable for a vast range of body heights, sizes and abilities. This model is the most popular with Pilates teaching studios and physios as it is very sturdy and has lots of flexibility to cater for all exercises. Our Pilates equipment is manufactured from high-quality materials, built to the European safety standard CE and has been carefully crafted incorporating clever designs to simplify operator use. Standard options of our Pilates machines provide quick adjustments without lengthy operation.

Specifications:

- Adjustable Pulley Risers with swivel pulleys provide ergonomic angle of ropes
- Durable braided ropes with cleated rope-clamping system for easy access and adjustability
- Adjustable high-density padded headrest (3 positions) for neck support
- Removable high-density padded shoulder rests
- Double-loop straps provide 3 different grip configurations (hand/foot/sandal) for a wider range of Pilates exercises
- Wide high-density EVA foam Padded Carriage is soft but supportive
- Adjustable feet-anchor strap at base for stability and posture while performing additional exercises
- Beautiful hand-sanded beech wood frame.

Features:

- The new 8-wheel "dual-angle treaded roller" system with high-quality bearings and stainless steel rails for quiet operation and the smoothest carriage glide
- Five deluxe smooth springs, 2x green (light resistance) 2x yellow (medium resistance) 1 x red (hard resistance)
- Detachable padded jump board (included)
- Large Sitting box (included)
- Built-in standing platform (included)
- Quick-Release Adjustable foot bar with non-slip padding

NJ-1004

LADDER BARREL

The Pilates Ladder Barrel is unique. It offer both active and passive back extension exercises. Of course as with all the pilates equipment it is designed to allow many other exercises to be performed.

The Pilates Equipment barrels are excellent for developing back strength and promoting trunk extension which is crucial to developing good posture.

Pilates Barrels utilize gravity rather than springs for resistance.



NJ-1005

WUNDA CHAIR

Popular in rehab, and studios, the Wunda Chair is finding its way into more and more homes, as more and more people are learning the value of low-impact resistance training.

Features include:

- Strong solid wood frame for sturdiness
- Beautiful multi-layered laminated wood with satin finish
- Comfortable high-density EVA foam padding with durable non-slip black vinyl
- 4x Medium Deluxe stainless steel springs
- Padded foot/hand pedals
- Two adjustable non-slip stainless steel stability handles



NJ-1006A

SPINE CORRECTOR

The Spine Corrector is the ultimate piece of equipment for aligning and mobilising the spine and can also contribute to an improved posture. As a diverse Pilates tool, it can also be used to perform exercises lengthening and strengthening the torso, shoulders, back and legs while correcting or restoring the spine's natural curvature.



OUR CLIENTS...

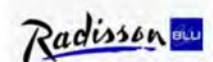

WE DESIGN YOUR FITNESS PROJECT



GYM DESIGN

Our in-house professional design team create gym layout and propose interior schemes to maximise your investment potential in terms of user demand and diversity. Making the best use of available space and incorporating natural features, branding and equipment selection, these are visualized 2D and 3D format with full 3D-rendered animations also available.

A COMPLETE SOLUTION

With more than 12 years experience of running of our own gyms plus unrivalled business planning, operational and management experience, Viva Fitness has the know-how to plan & budget your project along with the hands-on management, qualified expertise and staffing resources to partner you every step of the way towards your ultimate success.



Scan for downloading the complete catalogue

VIVA[®]
FITNESS

Push Yourself

DYNAMIK
GYMS

INTERNATIONAL HEADQUARTERS

235 CLIFTON BLVD
CLIFTON NJ 07011
USA



www.dynamikgyms.in

Regal Fitness

GROUP OF REGAL SPORTS SINCE 1938

REGAL SPORTS CO.
127 MG ROAD, SECUNDERABAD.
PH : +91-40-27842346, 27840692
Email : regalfitness@gmail.com
info@regalplay.com

ANDHRA PRADESH

+91 9347385566

SHOWROOM

SECUNDERABAD : +91-9848023658

GACHIBOWLI : +91 9391027124

JUBILEE HILLS : +91-9640006607

www.regalfitnessindia.com

www.tunturi.com

www.vivafitness.net

www.irelaxindia.com

MALKAJGIRI

+919396895599

GYM SET UP ALL INDIA

+919948819172

VANASTHALIPURAM

+91 9347385566

* All pictures / models are indicative * Design and price is subject to change without prior notice * Conditions apply * Local taxes & octroi extra as applicable.

* All pictures / models are indicative * Design and price is subject to change without prior notice * Conditions apply * GST extra